

User Guide

CCS2 Controller

Please completely read this document and the contained safety instructions and note all given information before usage.

Please maintain the confidentiality of this user guide. It is intended solely for usage by people professionally associated with the product. If you are not the intended recipient, you may not disclose or use the information in this documentation. The information does not constitute an offer or solicitation to buy or sale of any security.

This user guide's text and illustrations have been meticulously crafted. However, we may not be held accountable for any discrepancies or failure consequences.

Some company and label names are protected by a label, a patent, or a trademark.

Copyright ©

Address: Bacancy Systems PVT LTD,
15-16, Times Corporate Park,
Near, Thaltej-Shilaj Road,
Opp. Stone Flats, Thaltej
Ahmedabad, Gujarat,
India, 380059

Website: www.bacancysystems.com

Phone: +91 90160 28817

All rights reserved, including disposal, exploitation, reproduction, editing, distribution, as well as and utilisation for intellectual property rights.

Liability

The given data is primarily for product description reasons and should not be considered a guaranteed characteristic unless specifically stated in the contract. All rights are retained with regard to the content of this documentation and the availability of the product.

DISCLAIMER

The product, product data and any of its specifications are subject to change without notice. Bacancy Systems PVT LTD, its employees, and all persons acting on its behalf shall not be liable for any errors, inaccuracies, or incompleteness that occur if the methodology contained herein or in any other revelation of the product is not followed. The product specifications alter or amend neither the terms nor conditions of purchase nor the warranty expressed therein.

Bacancy Systems PVT LTD offers no warranty, representation, or guarantee other than as set forth in the terms and conditions of purchase. To the maximum extent permitted by applicable law.

Bacancy Systems PVT LTD, Disclaims

- (i). Any and all liability arising out of the application or use of any product.
- (ii). Any and all liability, including without limitation special, consequential or incidental damages.
- (iii). Any and all implied warranties, including those of merchantability, fitness for a specific purpose, and non-infringement.

The information provided in user guide and/or specifications may differ from actual results in different circumstances, and efficiency may change over time. Statements on a product's appropriateness for a certain application are based on Bacancy Systems PVT LTD's understanding of standard demands that are frequently put on the products of Bacancy Systems PVT LTD. The customer should determine whether a given Bacancy Systems PVT LTD product with the features mentioned in the product specification is appropriate for use in a specific application.

The product shown herein is not designed for use in lifesaving or life-sustaining applications unless otherwise expressly indicated. Customers who utilise or sell Bacancy Systems PVT LTD products that are not explicitly intended for such applications do so solely at their own risk.

This user guide is intended to improve the operator's efficiency throughout the procedure and does not entirely absolve them of responsibility.

Change Record

Rev. No.	Date	Details	Revised By	Approved By
1	27/03/2024	Initial Release	Nikunj Bambhroliya	Kanj Viroja
2	09/04/2024	<ul style="list-style-type: none"> • Resize the images and make minor modifications in the technical explanation. • Updated hardware connections and characteristics. • Updated wiring diagram for 60kW. 	Jasmin Nakrani	Kanji Viroja
3	06/06/2024	Contact Details	Nikunj Bambhroliya	Kanji Viroja
4	22/04/2025	Legal Entity Conversion: LLP to PVT LTD	Rajkumar Patel	Kanji Viroja
5	13/06/2025	Section 7.2: Mandatory Label for Prerequisites	Chirag Rana	Kanji Viroja

Table of Contents

1	About this Document	7
1.1	Information on the Manual	7
1.2	Limitations of Liability.....	7
2	Safety	8
2.1	Safety Graphical Pictogram or Symbol	8
2.2	Safety Instruction and Warnings	9
2.3	The Responsibility of Operator	10
2.4	Person in Charge of Operations	10
2.5	In an occurrence of Danger or an Accident.....	11
3	Packaging, Transport and Storage	12
3.1	Inspection Packaging and Transport.....	12
3.2	Transport.....	12
3.3	Storage.....	12
4	Intended Use	13
4.1	Limitation	13
4.2	Alteration and Restoration of the Product/System.....	13
4.3	Prerequisites	13
5	Structure and Functions	14
5.1	Supported Software and Hardware Platforms	14
5.2	Reference.....	15
5.3	Support.....	15
6	System Overview	16
6.1	Features	17
6.2	Technical Specification	17
6.3	Limitations and Assumptions	19
6.4	Firmware Flashing Instructions	19
6.5	CCS2 Controller Operations	20
7	Technical Description	22
7.1	List of Hardware Components	22
7.2	Hardware Connections	22
7.2.1	Power Supply Connection with CCS2, PLC, LED and RFID Module.....	22
7.2.2	PLC/CAN Controller Interface	23
7.2.3	Rectifier Module Interface	23
7.2.4	AC Meter, RFID and LED Board Interface	23
7.2.5	Digital Output Pin interface	24

7.2.6	Digital Input Pin Interface.....	24
7.2.7	HMI Display Interface	24
7.2.8	Temperature Gun Interface.....	25
7.2.9	GSM Addon board Interface	25
7.2.10	LED Module Hardware Interface.....	26
7.2.11	Miscellaneous Interface	26
7.3	DI and DO Electrical Characteristics.....	27
7.4	Hardware Connector Position	28
7.4.1	Master Controller	28
7.4.2	PLC/CAN Controller.....	28
7.4.3	LED ADDON Module	29
8	Appendix	30
8.1	LED Indication Pattern Information	30
8.2	Wiring Diagram.....	30
8.3	Abbreviations and Glossary	36

List of Figures

Figure 1	Safety Instruction	8
Figure 2	Power Supply Connection with CCS2, PLC, LED & RFID Module.....	22
Figure 3	PLC/CAN Controller Interface	23
Figure 4	Rectifier Module Interface	23
Figure 5	AC Meter, RFID and LED Board Interface.....	23
Figure 6	Digital Output Pin Interface	24
Figure 7	Digital Input Pin Interface	24
Figure 8	HMI Display Interface.....	24
Figure 9	Temperature Gun Interface	25
Figure 10	GSM Addon Board Interface	25
Figure 11	LED Module Hardware Interface	26

List of Tables

Table 1	Safety Graphical Pictogram or Symbol.....	8
---------	---	---

1 About this Document

1.1 Information on the Manual

This user guide contains basic information to be considered in the utilisation of the product. A precondition for safe working is the observance of all stated safety instructions and directions. Therefore, this user guide should be read and applied without fail by any person assigned to the installation and operating procedures of the product or system.

This user guide is part of the product, and the case may have to be passed to third parties or the following owners. It must be permanently kept at the usage site and be available for the operating personnel who are responsible for the installation of this product or system.

We are eager to ensure the comprehensiveness, relevance, and up-to-dateness of this user guide. It may become essential to make spontaneous changes to the product and its operation, which may not align with this manual, to maintain our technical advancement. In that case, Bacancy Systems PVT LTD will provide you with a new manual. We exclude liability for disturbances, failures, and resulting damages.

The illustrations in this user guide will provide a better understanding. It can occur that illustrations are not drawn to scale or deviate somewhat from the original.

1.2 Limitations of Liability

All statements and remarks in this user guide have been aggregated with consideration of current standards, laws, and regulations, the state of technology, as well as our extensive knowledge, long-time expertise, and experience. In special models, due to demands for additional order options or the latest technical alterations, the actual scope of delivery can differ from the explanations and elaborations described here.

The manufacturer excludes any liability for damages caused by:

- Inappropriate assembling and installation.
- Non-observance of the user manual.
- Non-intended and improper use.
- Use beyond operation limits.
- Deployment of insufficiently qualified and trained personnel.
- Use of unauthorised spare parts and accessories.

2 Safety

The safety directions, cautions, warnings, and notices are stated here. Moreover, in this user guide's section, the following sections have to be followed to reduce potential health risks and prevent hazardous situations as per the ISO 45001:2018 standard for occupational health and safety.

2.1 Safety Graphical Pictogram or Symbol

These prescribe safety signs for the purposes of accident prevention, fire protection, health hazard information, and emergency evacuation as per the ISO 7010:2019 standard for graphical symbols, safety colours, and registered safety signs.

The safety instructions are structured as follows:

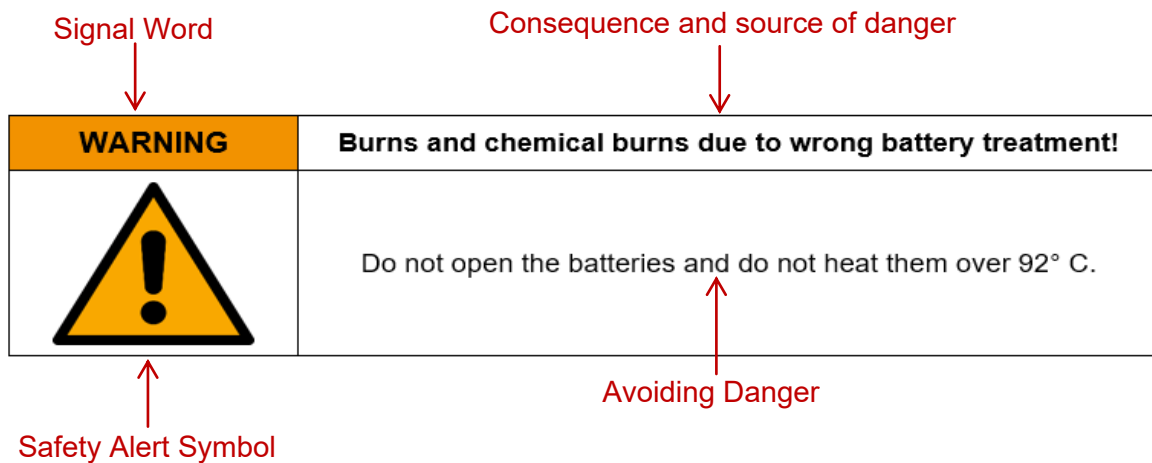











Figure 1 Safety Instruction

Table 1 Safety Graphical Pictogram or Symbol

Pictogram / Symbol	Signal Word	Meaning
	DANGER!	In case of non-compliance with this safety instruction, death or serious injury will occur.
	WARNING!	In case of non-compliance with this safety instruction, death or serious injury can occur.
	CAUTION!	In case of non-compliance with this safety instruction, a minor or moderate injury can occur.
	NOTICE!	In case of non-compliance with this safety instruction, material damage can occur.
	NOTE!	Useful notice or tip on the products or system's easy operation.

2.2 Safety Instruction and Warnings

MANDATORY	Read User Guide
	To get an understanding of the product, the user should pay careful attention to the user guide.
PROHIBITION	Hot Works
	Hot work shall be prohibited in close proximity to fully charged batteries. It will result in a battery explosion.
CAUTION!	Working with Machine Tools Near the Battery
	To prevent the occurrence of sparks, short circuits, or explosions, the user shall take precautions near the operation of a machine tool with a battery.
PROHIBITION	Installation Environment Circumstance
	High concentrations of oxidising or salted gases, wet or dusty surfaces, proximity to sources of extreme heat, open flames, or sparks, or high variation with temperature, proximity to storage of highly flammable materials or gas concentrations, and proximity to areas unprotected from water or high humidity are all prohibited.
MANDATORY	Installation and Maintenance
	Installation and maintenance should be carried out under the supervision or advice of a qualified professional.
PROHIBITION	Assembly and Disassembly
	The assembly or disassembly of an open, repaired, default parameter, or changed production should be prohibited. The warranty could be void and invalid, and the service can be discontinued without notice. The use of a high-pressure washer to clean the product is prohibited.

CAUTION!	To Insert a SIM Card or Memory Card
	The user should not insert a SIM card or memory card (SD card) into the product while it is in operation or connected to power.

WARNING!	Preventive Measures for Electro-Static Discharge (ESD)
MANDATORY	
	The user should avoid touching the product or its interface pins with their bare hands. The use of gloves while handling the product is mandatory.

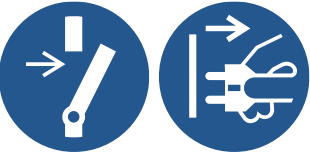
MANDATORY	Disconnect Power Supply
	The power source or plug should be disconnected in the event of an unanticipated event or when conducting maintenance and repair.

FIRE PROTECTION	Fire Extinguisher
	In the event of a fire, the use of a dry powder fire extinguisher should be advised for fire control, and the use of water should be prohibited.

2.3 The Responsibility of the Operator

The product is associated with industrial safety standards. However, the operator who is installing or operating the product is liable for the legal responsibilities for operational safety. In addition to the operational safety instructions in this manual, the safety, accident prevention, and environmental protection regulations valid for the operational area of the product shall be followed.

2.4 Person in Charge of Operations

WARNING!	Risk of injury caused by lack of an adequate qualification!
	Inappropriate handling of the product can lead to severe personal injuries and material damages.

In this manual the following qualification are specified:

Instructed Person	An instructed person is someone who has been instructed by the operator or manufacturer on the given tasks and potential hazards in the event of incorrect behaviour, as well as being semi-skilled and knowledgeable about the necessary safety procedures and safeguards.
Qualified Specialised Professional	Qualified specialised professionals are individuals who are knowledgeable with the assembly, commissioning, and operation of the product and process qualifications related to their work. The specialised individual is able to recognise hazards and prevent potential hazards because of their professional training, knowledge, and experience, as well as their understanding of the appropriate regulations.

2.5 In an occurrence of Danger or an Accident

Preventive Measures:

- Always be prepared for accidents or fires!
- Keep first-aid equipment (ambulance boxes, blankets, etc.) within easy reach.
- Inform personnel with accident alerting, first-aid, and emergency services.
- Keep clear access routes for emergency vehicles.

If the occurrence happens, follow these steps:

- Turn off the product immediately.
- Implement first-aid procedures.
- Get people out of hazardous areas.
- Inform the appropriate person at the usage spot.
- Contact a doctor and/or the fire department.

3 Packaging, Transport and Storage

3.1 Inspection Packaging and Transport

The products have been properly secured to ensure sufficient safeguarding during shipment. Please scrutinise the delivered products for overall quality and transportation problems as soon as possible.

In the instance of external shipment damage, proceed as follows:

- Do not accept delivery or accept it only on reserve.
- Issue a complaint.
- Do not use items that are obviously defective.

3.2 Transport

Always ensure that your equipment is transported in safe and appropriate containers while transporting it to the usage location or in the field.

Never transfer everything in an unplanned way in the vehicle. Hits and thrusts might seriously impair the product's functionality.

Always use the original packaging, transport containers, transport boxes, or equivalent packaging, whether transporting by train, aircraft, or ship. The container shields the goods from impacts and vibrations.

3.3 Storage

Strictly store the product in well-ventilated, dry spaces. During storage, keep it dry and leverage the original packaging if possible.

Avoid extreme heat fluctuations during storage. The initiation of water condensation can impair the product's operation.

When storing, keep in mind the temperature restrictions of the product. Please refer to the product's technical data for valid storage temperatures.

4 Intended Use

This document is intended to guide a user and provide information on the proper use of the CC2 controller or its functionality. Its purpose is to provide a comprehensive insight into the CCS controller, explain how to setup it with brief technical details, and address various technical aspects that could be associated with the CCS2 controller.

Furthermore, this document focuses on three aspects of the CCS2 controller: a system overview, hardware connections, and wire diagrams for the connection.

WARNING!	Risk caused by inappropriate use!
	<p>Any unconventional use and/or different operation of the product can lead to hazardous situations.</p> <ul style="list-style-type: none"> • Only use the product in a conventional manner.

4.1 Limitation

The product is intended for use in an operational environment. It should not be used in hostile or explosive conditions.

The operator should consult local safety authorities and safety representatives before performing tasks in hazardous areas or in similar circumstances.

4.2 Alteration and Restoration of the Product/System

To prevent risks and make sure optimal performance, no alterations, attachments, or restoration of the product are permitted without explicit authorisation of Bacancy Systems PVT LTD.

4.3 Prerequisites

These are the necessary tools or modules for configuring the CCS2 controller's settings. Without the tools specified here, the user should not proceed with the configuration procedure. Some tools are essential, such as the Segger JTAG, OCPP Flasher, PCAN, and SD cards.

We presume the customer already has a CCS2 controller board with a PLC converter. The firmware of the CCS2 controllers is pre-loaded. However, upgrading firmware requires a Micro SD card with a maximum storage capacity of 32GB and a binary files, which will be provided by the Bacancy Software Team.

This document does not address any other peripheral concerns.

5 Structure and Functions

5.1 Supported Software and Hardware Platforms

The functionality of the CSS2 Controller has been performed using the following setup of peripherals, software versions, and hardware platforms: Other peripherals, software, and hardware versions should be compatible with the CCS2 controller capabilities.

Bacancy does not promise that the CCS2 Controller will operate in any configurations other than those listed here:

List of Feature

Hardware Borad Version	ACDC3S2-2212-3A-01
Firmware Version	0.2.21 and above

List of Peripherals

CCS2 Controller
PLC
AC Meter
Insulation Monitoring Devices
Relay Module
HMI Display
Rectifier Modules (TONHE, MAXWELL, UUGREEN, SICON)
AC Contactor
DC Contactor
DC Fuse
SPD
RCCB
RFID Module
LED Module

NOTE!	List of Peripherals
	Bacancy uses the peripherals mentioned above to do a complete charger examination.

5.2 Reference

List of Document	Provided By
EVSE Commissioning Mobile Application	Bacancy
HMI-User Guide	
CCS2 CDM Application	
Troubleshooting Guide	
Flashing Guide	
PLC Configuration	

5.3 Support

Feel free to contact Bacancy's technical support team if you need help or have queries regarding Bacancy's CCS2 Controller.

6 System Overview

The CCS2 controller is developed to function as a Supply Equipment Communication Controller (SECC) between the communication medium for electric vehicles (EVs) and electric vehicle supply equipment (EVSE). It is an integral component of a charging station, and it offers a configuration that incorporates the standards specified by DIN 7012, ISO 15118, plug and charge (PnC) and Plug and Play (PnP), particularly for a fast DC charger. Moreover, the CCS2 controller allows the user to integrate additional components with DC chargers, such as

- Power Modules
- Insulation Monitoring Device
- AC / DC Energy Meter
- RFID Module
- OCPP

Block Diagram:

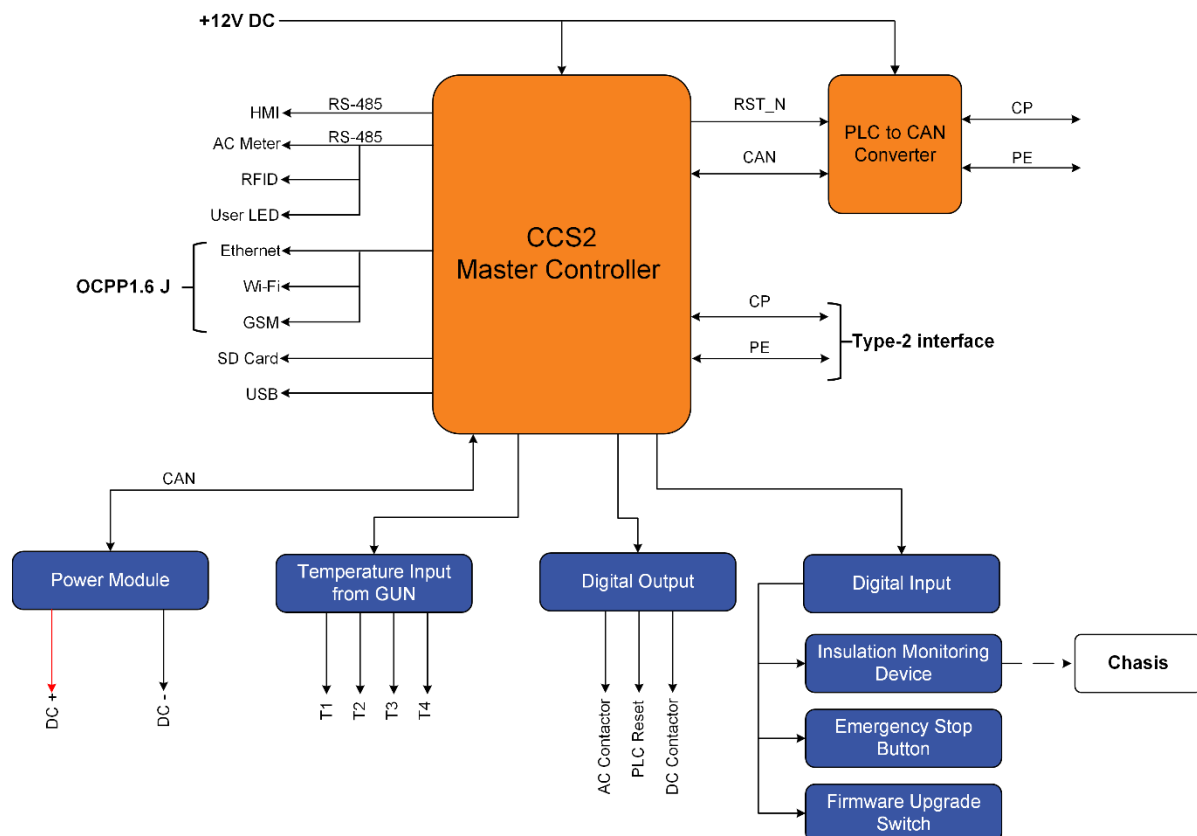

6.1 Features

List of Feature	
Compliance	ISO/IEC 15118 and DIN 70121
Support	Dual CCS2 Interface
	Single Type-2 AC Interface
	RFID based user Authorisation
	HMI Interface to display charging data over Modbus
	OCPP 1.6j (upgradable to OCPP2.0.1 Configuration)
PWM control for motor and fan support	
Suitable Charger	Up to 120kW

6.2 Technical Specification

Electrical Properties	
Voltage	12 V DC @2A
Power	24 W
Connector	
Type of Connector Support	CCS2 + Type-2 AC
Number of Gun Support	3 (2 Guns of CCS & 1 Gun Type 2 AC)
Connector Type	IEC 60309 Industrial Socket
Interface Connection	
Vehicle Communication	Basic Signalling (BS) and High-Level Communication (HLC)
Network Connection	Ethernet, Wi-Fi 802.11 b/g/n and GSM (LTE, 4G, Fallback to 2G)
Power Module Interface	CAN 2.0
Bridge Interface	RS-232 to RS-485
HMI Communication Protocol	RS-485 (Slave)
RFID, LED, Meter, MID Energy Meter Communication	RS-485 (Master)
Any Sensor Interface (Including cabinet temperature monitoring)	I2C or Digital Input
Gun Temperature Measurement Input	4 Nos. RTD, PT1000 to Monitor Gun Temperature & Prevent Overheating
LED	3 Nos. LEDs Connector to Display Charger Status Indication
Insulation Monitoring Device	Digital Input
Load Balancing	
Dynamic (based on EV power demand)	
Digital Payment Support	
Optional POS Machine Integration	

Storage Memory

Micro-SD Card Supported; Expandable Storage up 32 GB

Digital Input / Output

Digital Input	4 Nos. (12 V logic)
Digital Output	7 Nos. (Open Collector)

Add-on Board

RFID Module (MF RC522, 13.56 MHz), LED Board, Cabinet Temperature Monitoring, and Liquid Cool Gun Monitoring Logic (Optional)

Environment Conditions

Degree of Protection	IP54
Operating Temperature	-20°C to +70°C
Storage / Transport Temperature	-20°C to +70°C
Permissible Humidity	5 to 95%

Mechanical Properties

Demission	210 (L) × 120 (B) × 59 (H) mm
Weight	610 g & 105 g (without enclosure)

Firmware Upgrade

Firmware Over-The-Air (FOTA) support Available

Standard Support

ISO 15118, DIN 70121, Plug & Charge (PnC), Plug & Play (PnP), Vehicle to grid (V2G), IEC 61851

Security Compliance

Real-time communication support for OCPP interfaces using secure (WSS) and non-secure (WS) Web Sockets.

The firmware upgrade via over-the-air supports both secure (https) and non-secure (http) communication channels.

Easy to be commissioning charger using the mobile application with secure login credentials.

The software utility is protected and managed by a central server system and requires a username and password for authorised access.

6.3 Limitations and Assumptions

- **Limitations**

1. Insulation monitoring device interface support via digital input line.
2. Meters interface support is provided using RS-485.
3. HMI interface support is provided using RS-485.

- **Assumptions**

1. We prioritise on ensuring that all third-party components and peripherals satisfy standards and maintain good quality without any compromises.
2. We presumptively believe that all wiring for the CCS2 Controller was done correctly and without any wiring problems.
3. We guarantee that the system functions as intended, and all modules will be CCS2 compatible.
4. The rectifier module shall have proper air ventilation.

6.4 Firmware Flashing Instructions

To upgrade the firmware on the CCS2 Controller board using the SD card, follow the steps listed below:

- Step 1.** Use the FAT32 file system to perform the firmware upgrade after formatting the SD card.
- Step 2.** Get the recent firmware file provided by the Bacancy team and copy it to your SD card path without a folder.
- Step 3.** Insert the SD card into the CCS2 controller board after removing it from the host Computer.
- Step 4.** Press the “MCU_RST” button on the CCS2 board while connecting Digital I/P pin 2 and ground (shorting).
- Step 5.** Remove the shorting between Digital I/P pin 2 and Ground after pressing the “MCU_RST” pin.

6.5 CCS2 Controller Operations

- **OCPP Server Configuration:** Refer to the commissioning process document.
- **Charging Cycle Procedure:** Refer to the procedure flow as shown in the below.

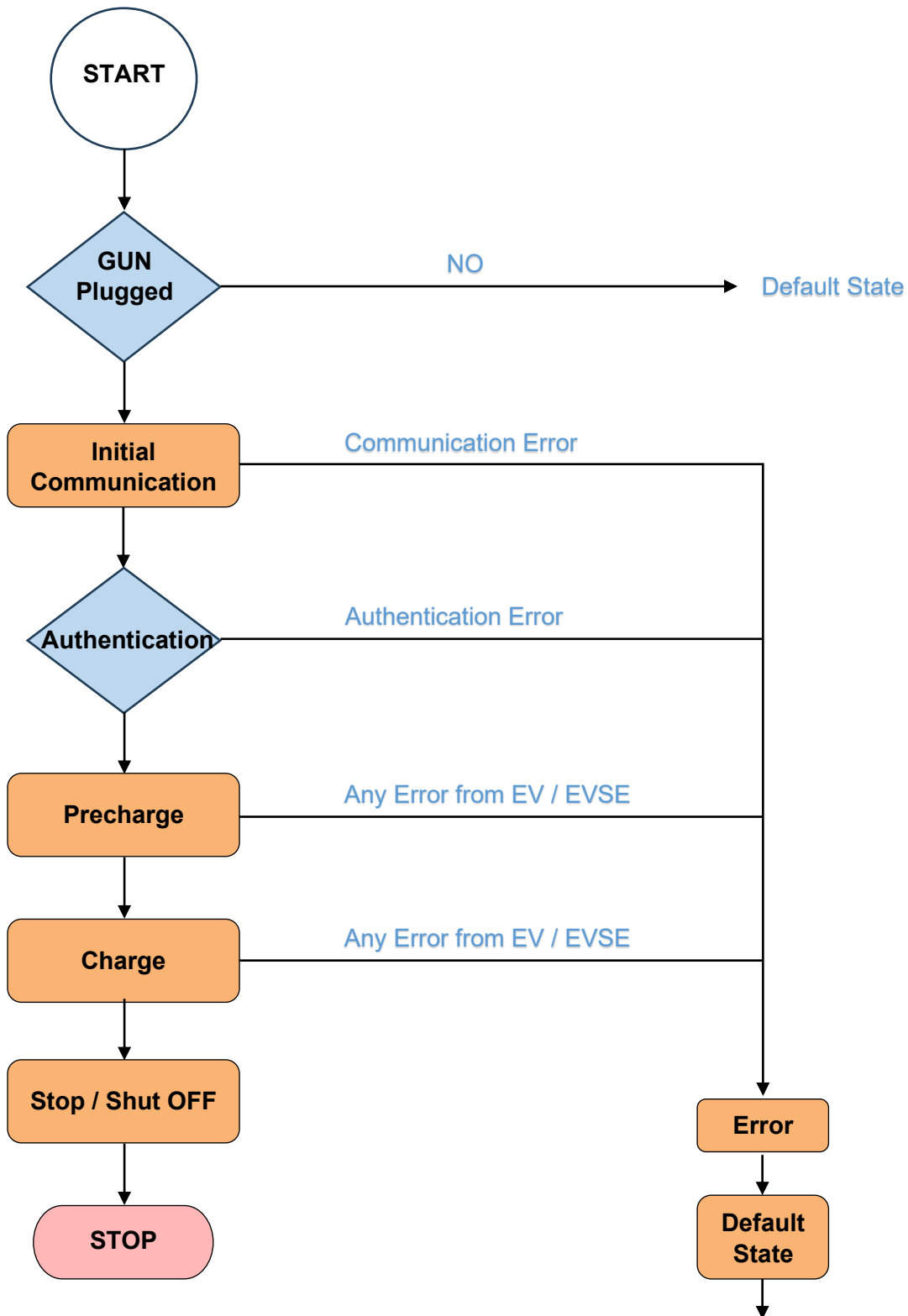

Unplug the Gun and Plug it after 10 Second.

- **Emergency Stop:** It should only be used in emergency circumstances to halt operations.
- **Troubleshooting:**
 - The user must be observant of errors indicated by the LED. To ensure safe operation, unplug the gun as soon as a problem arises.
 - The user should take the SD card out of the CCS2 controller board and send log files to the Bacancy team for further analysis.
 - The user can contact the Bacancy team for support if they face any further issues.

7 Technical Description

7.1 List of Hardware Components

MANDATORY	Mandatory general instruction to avoid improper usage!
	While performing operations or installation, a list of hardware should be mandated.

- List of Hardware**

- | | |
|--------------------------|--|
| 1. CCS2 Controller Board | 4. LED Module |
| 2. PLC/CAN Controller | 5. Peripheral Wire with Female Connector |
| 3. RFID Module | |

7.2 Hardware Connections

MANDATORY	Prerequisites for Power Supply and Shielded Cable
	The 12 VDC power supply* should be CE certified, and all communication with the controller should be conducted through a shielded cable that is connected to the earth cable. <i>(*Recommended Power Supply: Phoenix 1170955)</i>

7.2.1 Power Supply Connection with CCS2, PLC, LED and RFID Module

Pin Connection:

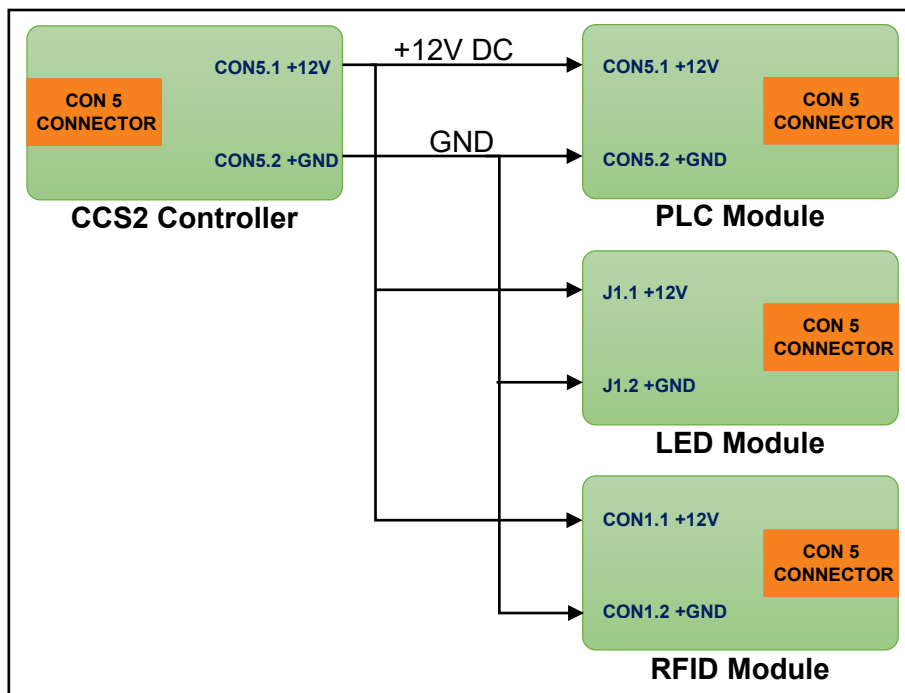

Figure 2 Power Supply Connection with CCS2, PLC, LED & RFID Module

7.2.2 PLC/CAN Controller Interface

Pin Connection:

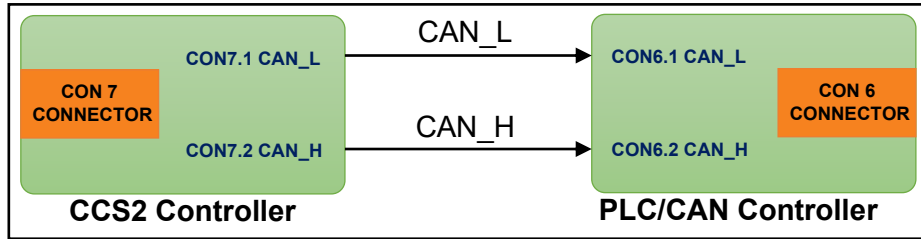

Figure 3 PLC/CAN Controller Interface

7.2.3 Rectifier Module Interface

Pin Connection:

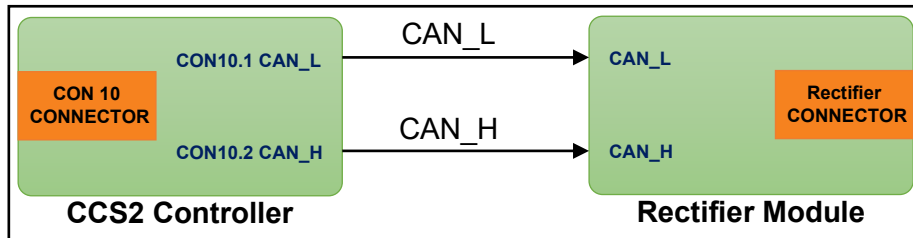

Figure 4 Rectifier Module Interface

7.2.4 AC Meter, RFID and LED Board Interface

Pin Connection:

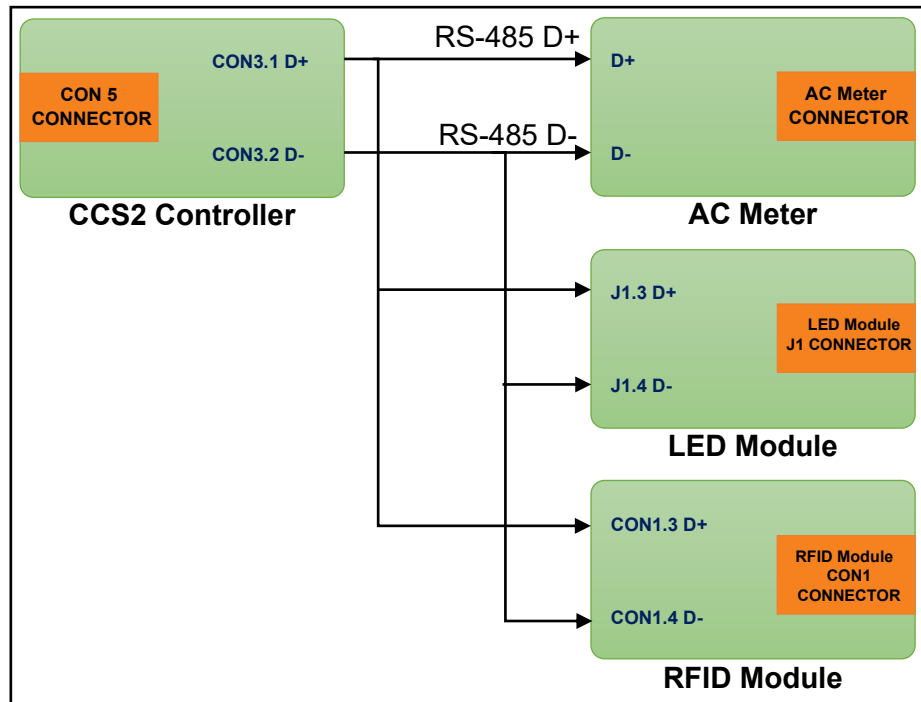

Figure 5 AC Meter, RFID and LED Board Interface

7.2.5 Digital Output Pin interface

Pin Connection

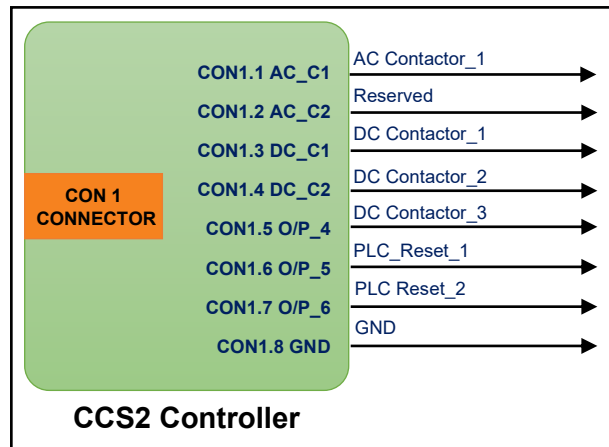

Figure 6 Digital Output Pin Interface

NOTE!	Useful Tip
	The active low level of an AC or DC contactor is similar to DO logic.

7.2.6 Digital Input Pin Interface

Pin Connection

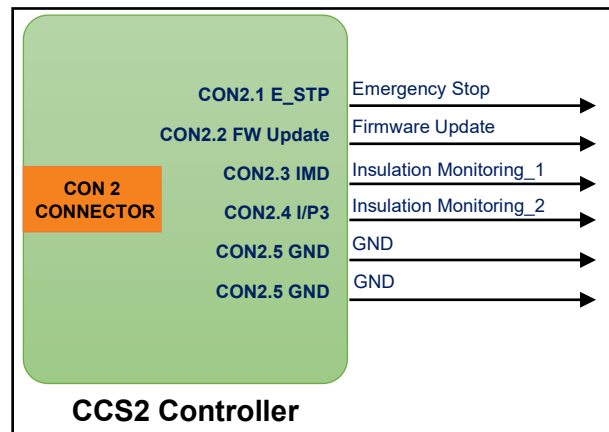

Figure 7 Digital Input Pin Interface

7.2.7 HMI Display Interface

Pin Connection

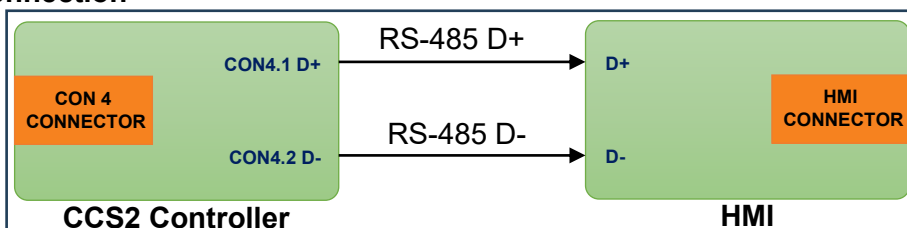

Figure 8 HMI Display Interface

7.2.8 Temperature Gun Interface

Pin Connection

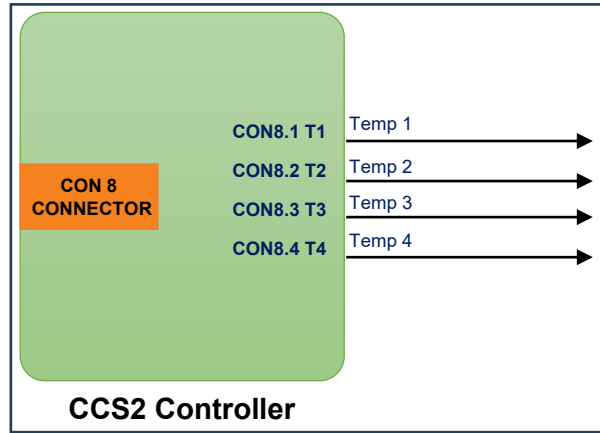

Figure 9 Temperature Gun Interface

NOTE!	Connector Number 9
	<p>The CON 9 is reserved for a dual gun.</p>

WARNING!	If CCS2 controller failure is caused by an inappropriate interface!
	<ul style="list-style-type: none"> Do not remove the 1K Ω resistance from CON9 with a female connection. When the gun is plugged in using the connector, the 1 KΩ resistance is removed from the connection.

7.2.9 GSM Addon board Interface

Pin Connection

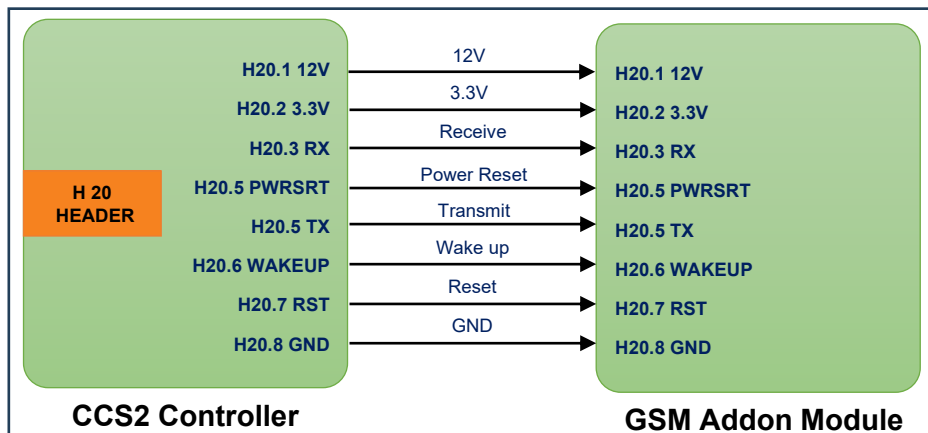

Figure 10 GSM Addon Board Interface

7.2.10 LED Module Hardware Interface

Connect the red, green, and blue LEDs to the LED module as per the pin connection as described below:

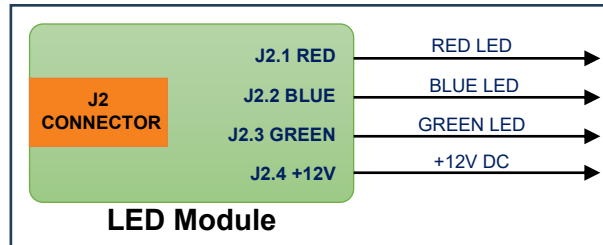



Figure 11 LED Module Hardware Interface

7.2.11 Miscellaneous Interface

- CCS2 Gun Connection with PLC module details:

NOTE!	Use Tip!
	<p>The user is required to connect the CP and PE pins of the gun to the PLC module.</p>

- Type-2 pins of CCS2 controller board details:
These pins are currently reserved but will be utilised for Type-2 connections.
- SD card slot S1 is for inserting SD cards, storing errors, and monitoring logs. The format for saving the logs is as follows:
 - Folder Name (**DD_MM_YYYY**)
 - Log File Name (**LOG_HH_MM_SS**)

'USB_0 or CON_1' can be used for console log information. For the time being, USB_1 is reserved.
- The H1, H7, H3, and H16 headers are employed for manufacturing purposes.

7.3 DI and DO Electrical Characteristics

Digital Input									
Pin	Voltage			Logic		Functional States			
	State	Min	Typ	Max	Default	Operating State	High	Low	Floating
Input 1 (Emergency Stop)	High	10.7	12V	18V	High	Active Low	Emergency Stop Detected	Emergency Not Stop Detected	Emergency Stop Detected
	Low	0V	0V	10.6V					
Input 2 (Firmware update)	High	10.7	12V	18V	High	Active Low	User Input Not Detected	FW Update Trigger	User Input Not Detected
	Low	0V	0V	10.6					
Input 3 (IMD update 1)	High	10.7	12V	18V	High	Active Low	IMD Module 1 Detected	IMD Module 1 Not Detected	IMD Module 1 Not Detected
	Low	0V	0V	10.6					
Input 4 (IMD update 2)	High	10.7	12V	18V	High	Active Low	IMD Module 2 Detected	IMD Module 2 Not Detected	IMD Module 2 Not Detected
	Low	0V	0V	10.6					
Forward Current	50mA (Max)								

NOTE!	Follow appropriated notes for Digital Input
	<ul style="list-style-type: none"> The software supports emergency stop and IMD action on the rising edge (low to high). When the CCS2 board is powered on, the emergency stop should be released. If an emergency stop was pushed or not connected, the board would not start. A firmware update will be enabled only when input pin-2 is connected to GND while the reset button is switched on simultaneously.

Digital Output (Open Collector)									
Pin	Voltage			Max Current		Logic		Functional States	
	Min	Typ	Max	Source	Sink	Default	Operating State	High	Low
Output 1 (AC Contactor 1)	0V	-	12V	1.2mA	600 mA	High	Active Low	AC Contactor 1 ON	AC Contactor 1 OFF
Output 2 (Reserved)	0V	-	12V	1.2mA	600 mA	High	Active Low	Reserved	Reserved
Output 3 (DC Contactor 1)	0V	-	12V	1.2mA	600 mA	High	Active Low	DC Contactor 1 ON (Reserved)	DC Contactor 2 OFF (Reserved)
Output 4 (DC Contactor 2)	0V	-	12V	1.2mA	600 mA	High	Active Low	DC Contactor 2 ON	DC Contactor 2 OFF
Output 4 (DC Contactor 2)	0V	-	12V	1.2mA	600 mA	High	Active Low	DC Contactor 3 ON (Reserved)	DC Contactor 3 OFF (Reserved)
Output 5 (PLC Reset 1)	0V	-	12V	1.2mA	600 mA	High	Active Low	-	PLC Reset 1
Output 6 (PLC Reset 2)	0V	-	12V	0.33mA	600 mA	High	Active Low	-	PLC Reset 2
Collector Current	600mA (Max)								

7.4 Hardware Connector Position

7.4.1 Master Controller

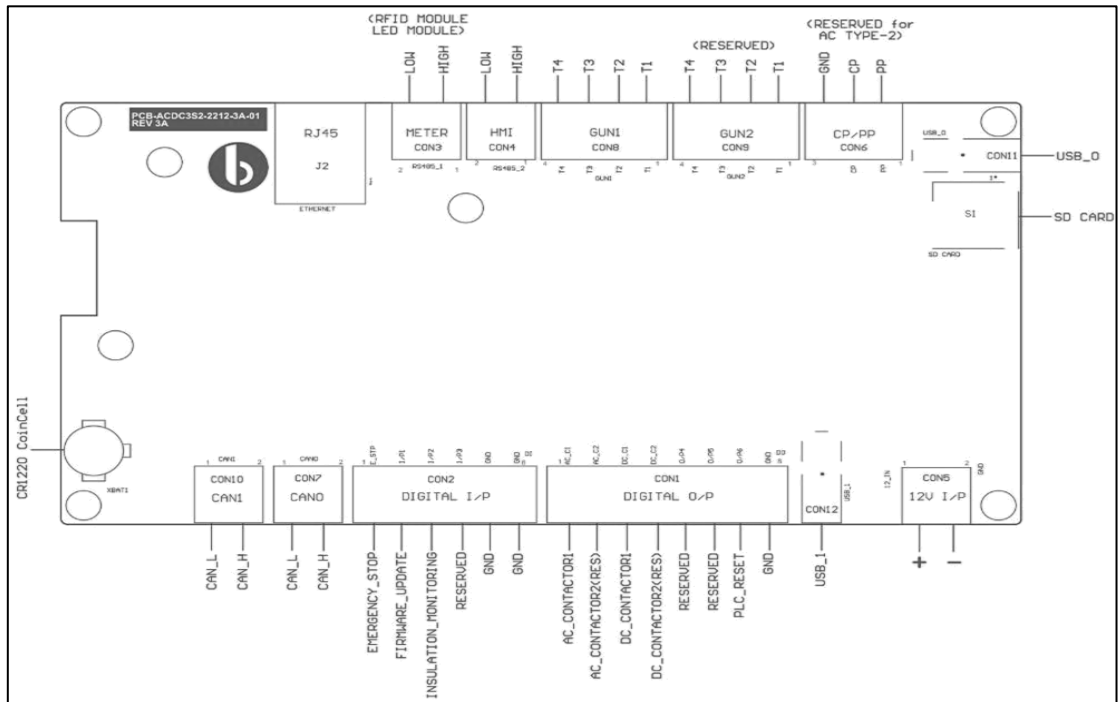

7.4.2 PLC/CAN Controller

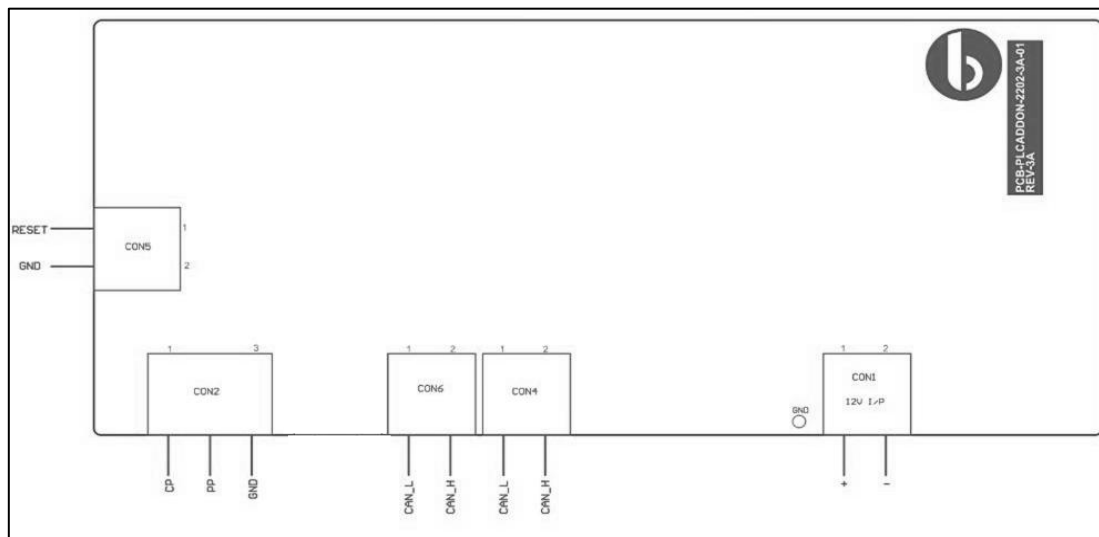



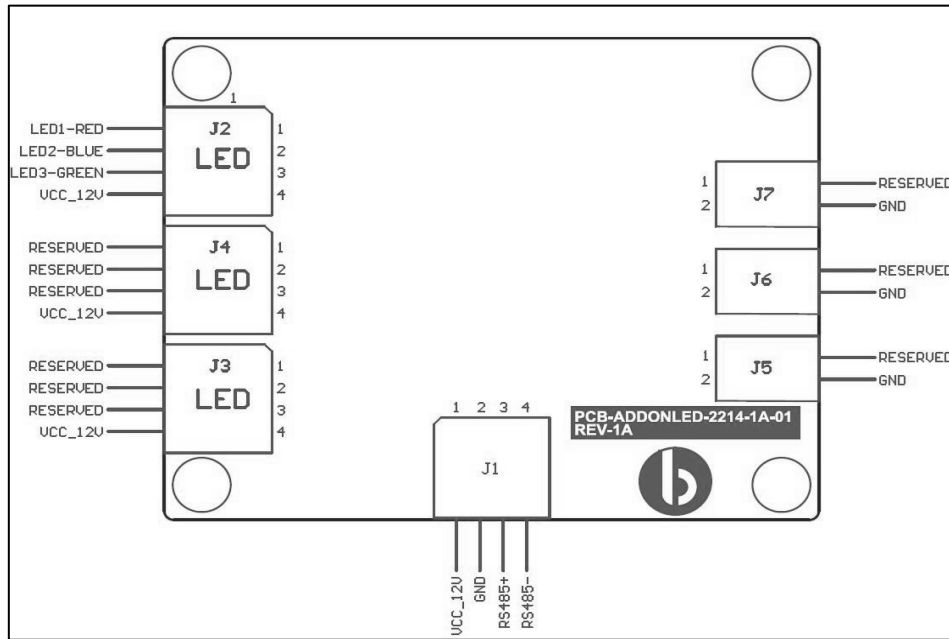

7.4.3 LED ADDON Module



8 Appendix

8.1 LED Indication Pattern Information

No.	LED Colour	LED Status	Action	
1	Blue		Blink	Power ON and EVSE disconnected from the server.
	Blue		Steady	Power ON & EVSE Connected to server
2	Green		Blink	EV Charging
	Green		Steady	Gun connected to vehicle but not Charging
3	Red		Steady	Error or Fault

8.2 Wiring Diagram

Please refer the next page.

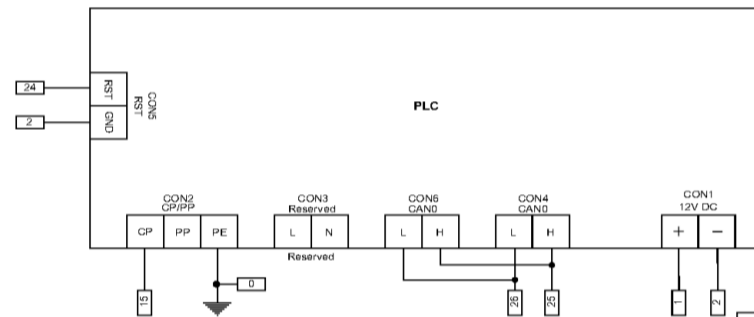
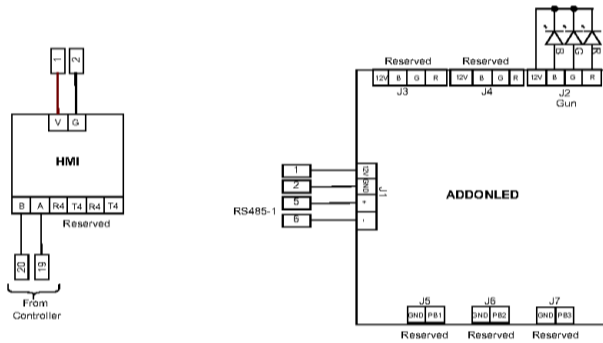
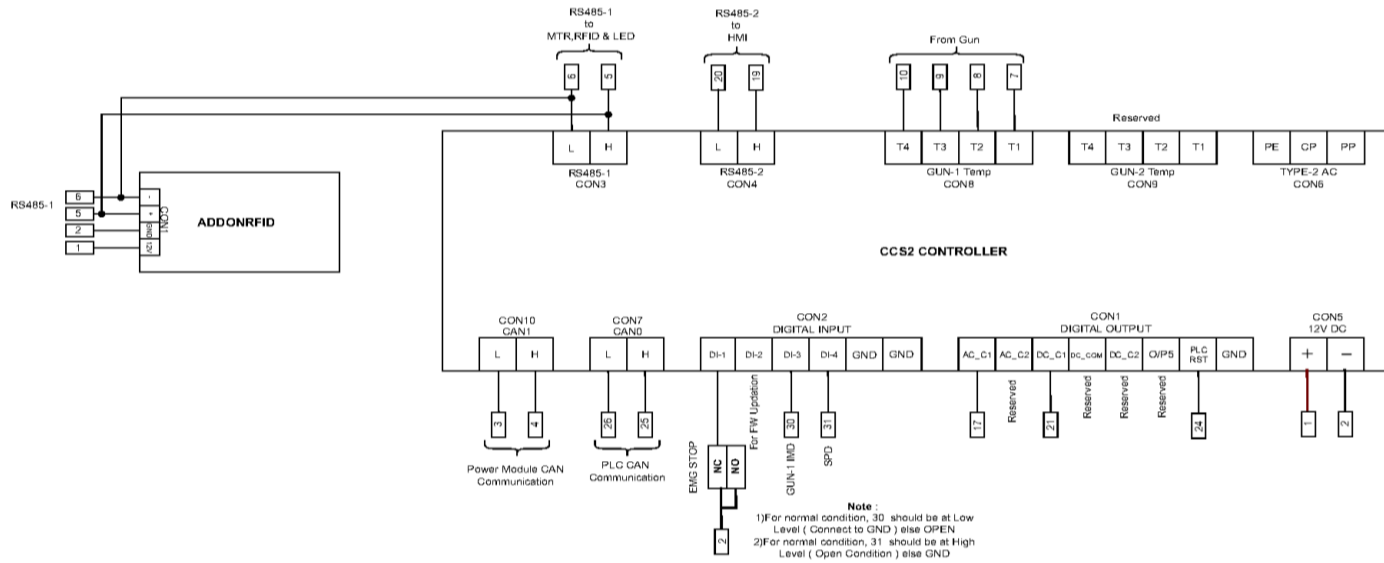

BACANCY[®]
SYSTEMS PVT LTD

SLD CCS2 Single GUN 30KW

Prepared BY : Jasmin Nakrani
Approved By: Hardik Sheth
Date : 24/04/2023

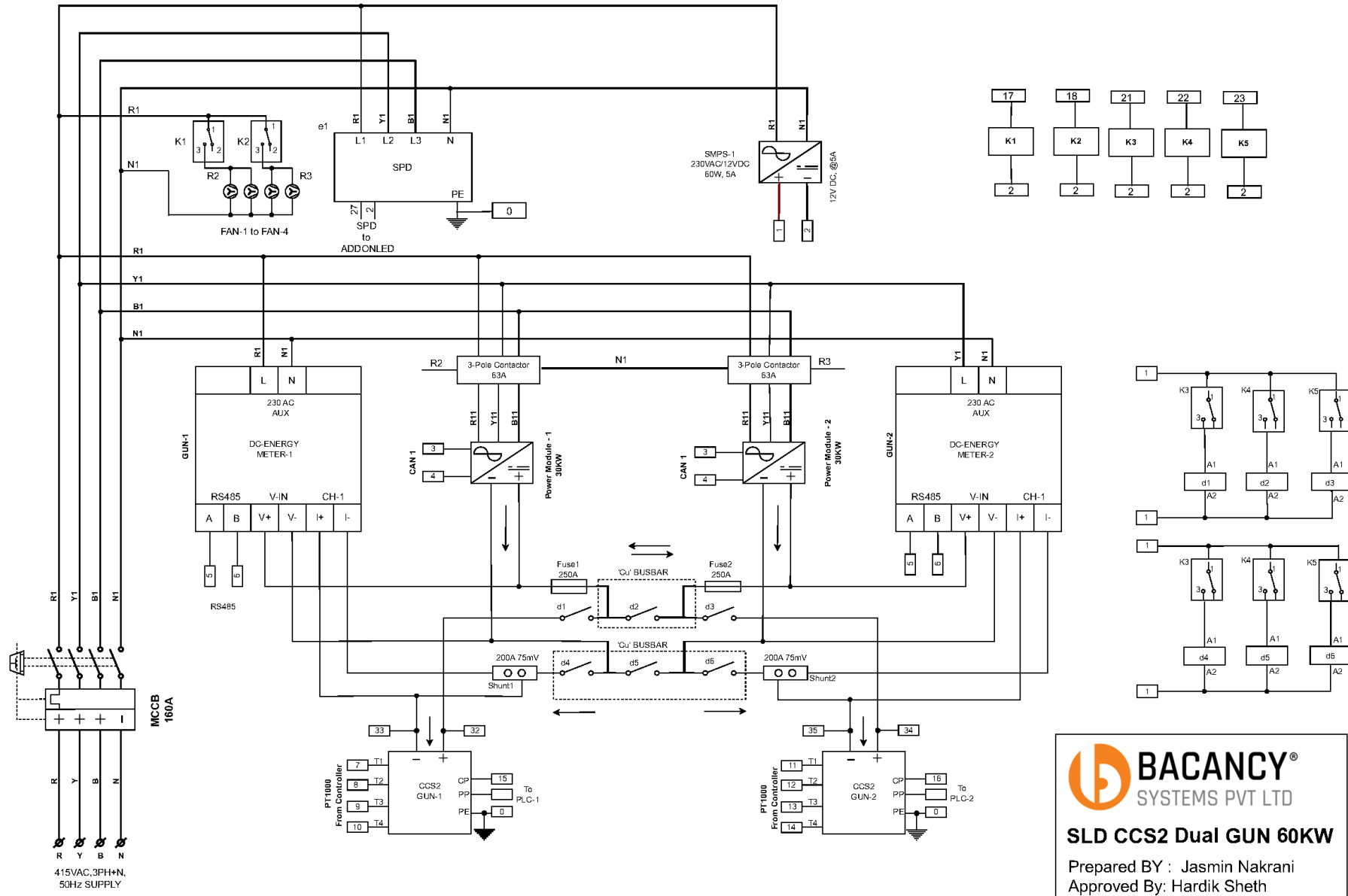

BACANCY[®]
SYSTEMS PVT LTD

SLD CCS2 Dual GUN 60KW

Prepared BY : Jasmin Nakrani
Approved By: Hardik Sheth

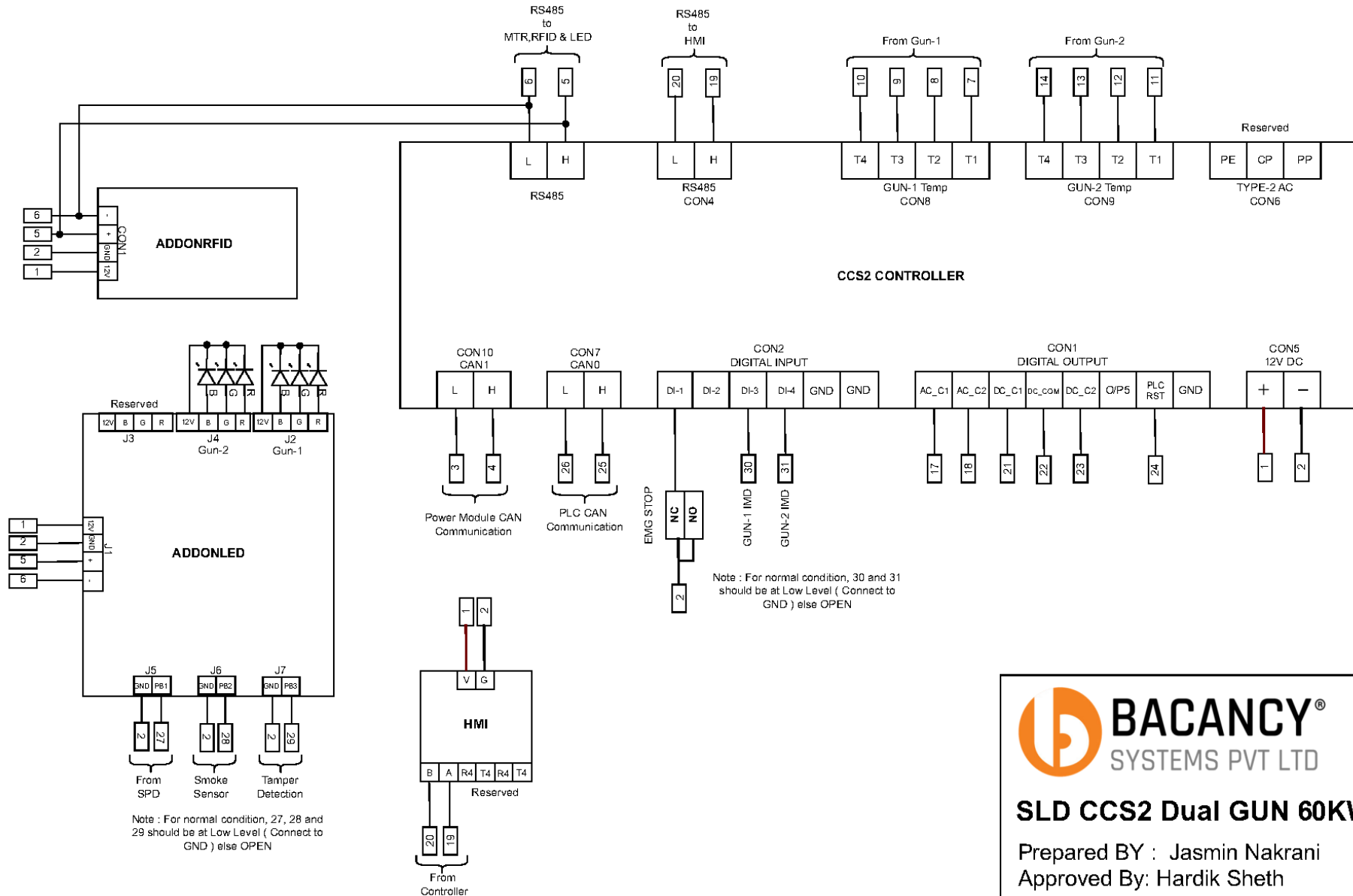

BACANCY[®]
SYSTEMS PVT LTD

SLD CCS2 Dual GUN 60KW

Prepared BY : Jasmin Nakrani
Approved By: Hardik Sheth

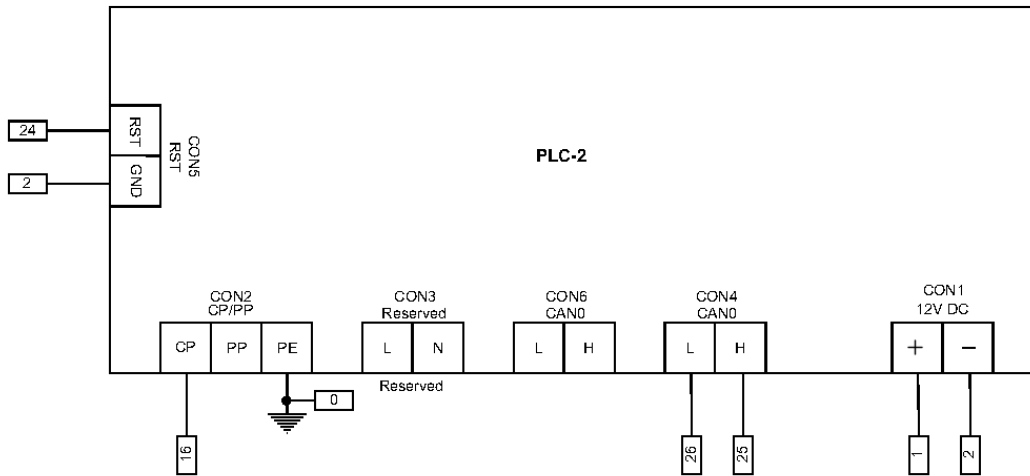
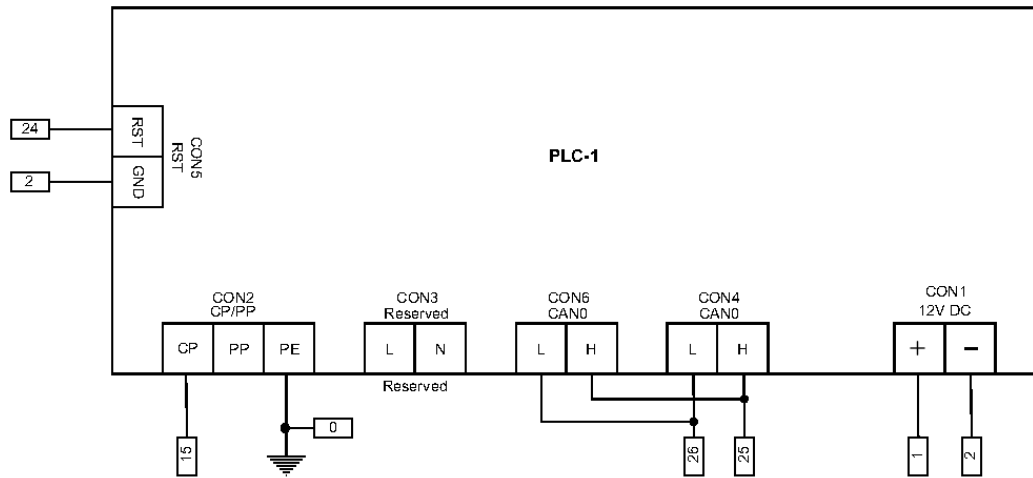

BACANCY[®]
SYSTEMS PVT LTD

SLD CCS2 Dual GUN 60KW

Prepared BY : Jasmin Nakrani
Approved By: Hardik Sheth

8.3 Abbreviations and Glossary

AC	<i>Alternating current, a type of electrical current in which the current repeatedly changes direction.</i>
CAN	<i>A controller area network (CAN) bus is a high-integrity serial bus system for networking intelligent devices. CAN busses and devices are common components in automotive and industrial systems.</i>
CCS2	<i>The Combined Charging System (CCS) is a standard for charging electric vehicles.</i>
CON	<i>Connector</i>
CP	<i>Control Pilot is a communication line used to negotiate charging level between the car and the EVSE, and it can be manipulated by the vehicle to initiate charging and can carry other information.</i>
DC	<i>Direct current (DC) is one-directional flow of electric charge.</i>
DIN 70121	<i>Digital communication between a DC EV charging station and an electric vehicle for control of DC charging in the Combined Charging System (CCS).</i>
EV	<i>An EV is defined as a vehicle that can be powered by an electric motor that draws electricity from a battery and is capable of being charged from an external source.</i>
EVSE	<i>Electric vehicle supply equipment (EVSE) supplies electricity to an electric vehicle (EV). Commonly called charging stations or charging docks, they provide electric power to the vehicle and use that to recharge the vehicle's batteries.</i>
FAT32	<i>The term FAT32 is an acronym for File Allocation Table 32. It is basically an extension to the file systems used previously that stores kits data in 32-bit chunks.</i>
FOTA	<i>Firmware over-the-air update is a updated that is downloaded by the device over the internet.</i>
GSM	<i>GSM stands for Global System for Mobile Communications. It's a standard that specifies how 2G (second generation) cellular networks operate.</i>
I2C	<i>I2C stands for Inter-Integrated Circuit. It is a bus interface connection protocol incorporated into devices for serial communication.</i>

IEC 60309	<i>IEC 60309 is a series of international standards from the International Electrotechnical Commission (IEC) for "plugs, socket-outlets and couplers for industrial purposes".</i>
IEC 61851	<i>IEC 61851 is an international standard for electric vehicle conductive charging systems</i>
IP	<i>Ingress protection (IP) ratings, which grade the resistance of an enclosure against the intrusion of dust or liquids.</i>
IS17017	<i>IS 17017 is the key electric vehicle charging standard in India</i>
ISO	<i>The International Organization for Standardization</i>
ISO 15118	<i>ISO 15118 specifies the communication between Electric Vehicles (EV), including Battery Electric Vehicles and Plug-In Hybrid Electric Vehicles, and the Electric Vehicle Supply Equipment (EVSE).</i>
kW	<i>Kilowatt (symbol: kW) is a unit of electric power.</i>
LCD	<i>A liquid-crystal display (LCD) is a flat-panel display or other electronically modulated optical device that uses the light-modulating properties of liquid crystals combined with polarizers.</i>
LED	<i>A light-emitting diode (LED) is a semiconductor device that emits light when current flows through it.</i>
LTE	<i>LTE stands for Long Term Evolution. It's a term used for the particular type of 4G that delivers a fast mobile Internet experience.</i>
MCU	<i>The Motor Control Unit (MCU) is an electronic module that interfaces between the batteries (DC power sources) and the motor (AC or BLDC). Its main task is to control the EV's speed and acceleration based on throttle input.</i>
OCPP 1.6	<i>The OCPP 1.6 (Open Charge Point Protocol) enables the integration between equipment from different manufacturers.</i>
PCAN	<i>PCAN is a synonym for PEAK CAN APPLICATIONS and is a flexible system for planning, developing and using Controller Area Networks (CAN).</i>
PWM	<i>Pulse-width modulation (PWM), also known as pulse-duration modulation (PDM) or pulse-length modulation (PLM) is any method of representing a signal as a rectangular wave with a varying duty cycle.</i>
PE	<i>A Protective Earth connection, earth ground or safety ground uses a protective conductor to direct a fault current safely into the earth and away from a human being in contact.</i>

PLC	<i>Programmable Logic Controllers (PLCs) are industrial computers, with various inputs and outputs, used to control and monitor industrial equipment based on custom programming.</i>
RFID	<i>Radio-frequency identification (RFID) uses electromagnetic fields to automatically identify, and track tags attached to objects.</i>
RS-232	<i>RS-232 stands for "Recommended Standard 232" and it is a type of serial communication used for transmission of data normally in medium distances.</i>
RS-485	<i>RS-485 is an industrial specification that defines the electrical interface and physical layer for point-to-point communication of electrical devices. The RS-485 standard allows for long cabling distances in electrically noisy environments and can support multiple devices on the same bus.</i>
SD Card	<i>Secure Digital, officially abbreviated as SD, is a proprietary, non-volatile, flash memory card format the SD Association (SDA) developed for use in portable devices.</i>
SPD	<i>The Surge Protection Device (SPD) is a component of the electrical installation protection system.</i>
Type-2 Connector	<i>The IEC 62196 Type 2 connector is used for charging electric vehicles, mainly within Europe, as it was declared standard by the EU.</i>
USB	<i>Universal Serial Bus (USB) is an industry standard that allows data exchange and delivery of power between many various types of electronics.</i>
Wi-Fi	<i>Wi-Fi is a family of wireless network protocols based on the IEEE 802.11 family of standards, which are commonly used for local area networking of devices and Internet access, allowing nearby digital devices to exchange data by radio waves.</i>

 **Bacancy Systems PVT LTD,**
15-16, Times Corporate Park,
Near, Thaltej-Shilaj Road,
Opp. Stone Flats, Thaltej
Ahmedabad, Gujarat,
India, 380059

 www.bacancysystems.com

 systems@bacancy.com

 +91 90160 28817

 **Helpdesk:** <https://bacancy.freshdesk.com/a/dashboard/default>