

# **User Guide**

## **Power Module 40 kW**

**Please completely read this document and the contained safety instructions and note all given information before usage.**

Please maintain the confidentiality of this user guide. It is intended solely for usage by people professionally associated with the product. If you are not the intended recipient, you may not disclose or use the information in this documentation. The information does not constitute an offer or solicitation to buy or sale of any security.

This user guide's text and illustrations have been meticulously crafted. However, we may not be held accountable for any discrepancies or failure consequences.

Some company and label names are protected by a label, a patent, or a trademark.

### **Copyright ©**

**Address: Bacancy Systems PVT LTD,**  
15-16, Times Corporate Park,  
Near, Thaltej-Shilaj Road,  
Opp. Copper Stone Flats, Thaltej  
Ahmedabad, Gujarat,  
India, 380059

**Website:** [www.bacancysystems.com](http://www.bacancysystems.com)

**Email:** [systems@bacancysystems.com](mailto:systems@bacancysystems.com)

**Phone:** +91 90160 28817

All rights reserved, including disposal, exploitation, reproduction, editing, distribution, as well as and utilisation for intellectual property rights.

### **Liability**

The given data is primarily for product description reasons and should not be considered a guaranteed characteristic unless specifically stated in the contract. All rights are retained with regard to the content of this documentation and the availability of the product.

## DISCLAIMER

The product, product data and any of its specifications are subject to change without notice. Bacancy Systems PVT LTD, its employees, and all persons acting on its behalf shall not be liable for any errors, inaccuracies, or incompleteness that occur if the methodology contained herein or in any other revelation of the product is not followed. The product specifications alter or amend neither the terms nor conditions of purchase nor the warranty expressed therein.

Bacancy Systems PVT LTD offers no warranty, representation, or guarantee other than as set forth in the terms and conditions of purchase. To the maximum extent permitted by applicable law.

### **Bacancy Systems PVT LTD, Disclaims**

- (i). Any and all liability arising out of the application or use of any product.
- (ii). Any and all liability, including without limitation special, consequential or incidental damages
- (iii). Any and all implied warranties, including those of merchantability, fitness for a specific purpose, and non-infringement.

The information provided in user guide and/or specifications may differ from actual results in different circumstances, and efficiency may change over time. Statements on a product's appropriateness for a certain application are based on Bacancy Systems PVT LTD's understanding of standard demands that are frequently put on the products of Bacancy Systems PVT LTD. The customer should determine whether a given Bacancy Systems PVT LTD product with the features mentioned in the product specification is appropriate for use in a specific application.

The product shown herein is not designed for use in lifesaving or life-sustaining applications unless otherwise expressly indicated. Customers who utilise or sell Bacancy Systems PVT LTD products that are not explicitly intended for such applications do so solely at their own risk.

This user guide is intended to improve the operator's efficiency throughout the procedure and does not entirely absolve them of responsibility.

## Change Record

Rev. No.	Date	Details	Revised By	Approved By
0	18/12/2024	Initial Release	Rajkumar Patel	Jasmin Nakrani
1	23/04/2025	Legal Entity Conversion: LLP to PVT LTD	Rajkumar Patel	Jasmin Nakrani
2	01/05/2026	Revised Email Address	Rajkumar Patel	Jasmin Nakrani

## Table of Contents

<b>1. About this Document.....</b>	<b>9</b>
1.1 Information on the User Guide.....	9
1.2 Limitations of Liability.....	9
<b>2. Safety.....</b>	<b>10</b>
2.1 Safety Graphical Pictogram or Symbol .....	10
2.2 Safety Instruction and Warnings .....	11
2.3 The Responsibility of Operator .....	12
2.4 Person in Charge of Operations .....	12
2.5 In an occurrence of Danger or an Accident.....	13
<b>3. Packaging, Transport and Storage.....</b>	<b>14</b>
3.1 Inspection Packaging and Transport.....	14
3.2 Transport.....	14
3.3 Storage.....	14
<b>4. Intended Use .....</b>	<b>15</b>
4.1 Limitation .....	15
4.2 Alteration and Restoration of the Product/System.....	15
<b>5. Structure and Function.....</b>	<b>16</b>
5.1 Overview .....	17
5.1.1 Feature .....	17
5.1.2 Application .....	17
5.2 Function.....	17
5.2.1 Technical Specification .....	17
5.2.2 Performance Curve.....	21
A. Input Voltage Curve .....	21
B. Output Voltage Curve .....	21
C. Environment Temperature Power Limit Curve.....	22
5.2.3 Block Diagram .....	23
5.2.4 Mechanical Diagram .....	24
5.2.5 Pin Configuration .....	26
A. Input Connector .....	26
B. Output Connector.....	26
C. Extension of Output Connector .....	27
<b>6. Installation.....</b>	<b>28</b>
6.1 Module .....	28
6.2 Connector.....	28

6.2.1	Connector Position and Size.....	29
6.3	Cable Selection .....	30
<b>7.</b>	<b>Operating Status .....</b>	<b>32</b>
7.1	Power Module Panel.....	32
7.2	Button.....	32
7.3	Indicator LED Light .....	35
A.	State Grid Protocol Indicator .....	35
B.	Bacancy Agreement Indicator .....	36
<b>8.</b>	<b>Operating Environment .....</b>	<b>37</b>
A.	Heat Dissipation.....	38
B.	Reference Design for Heat Dissipation of Power Module .....	40
<b>9.</b>	<b>Maintenance .....</b>	<b>42</b>
9.1	Preventive Instruction .....	42
9.2	Replacement .....	42
<b>10.</b>	<b>Appendix .....</b>	<b>44</b>
10.1	Dispose of Product .....	44
10.2	Abbreviations and Glossary .....	44

## List of Figures

Figure 1 Safety Instruction .....	10
Figure 2 Power Module 40kW .....	16
Figure 3 Input Voltage / Output Power Curve .....	21
Figure 4 Output Voltage / Output Current Curve .....	21
Figure 5 Output Power / Environment Temperature .....	22
Figure 6 Input Connector .....	26
Figure 7 Output Connector .....	26
Figure 8 Extension of Output Connector .....	27
Figure 9 The Connector of Power Module Installation .....	28
Figure 10 Connector Position and Size .....	29
Figure 11 Reference Diagram: .....	29
Figure 12 AC Input Connector Size .....	29
Figure 14 DC Input Connector Size .....	29
Figure 13 Reference Diagram: .....	29
Figure 15 Power Module Panel .....	32
Figure 16 Information Display Flow .....	32

## List of Tables

Table 1 Safety Graphical Pictogram or Symbol .....	10
Table 2 Input Connector.....	26
Table 3 Output Connector .....	26
Table 4 Extension of Output Connector .....	27
Table 5 Type and Specification for Cable.....	30
Table 6 Navigation Button.....	32
Table 7 Operation Buttons. ....	33
Table 8 Definition of Indicator LED Light .....	35
Table 9 Definition of State Grid Protocol Indicator .....	35
Table 10 Definition of Bacancy Agreement Indicator .....	36

## 1. About this Document

### 1.1 Information on the User Guide

This user guide contains basic information to be considered in the utilisation of the product. A precondition for safe working is the observance of all stated safety instructions and directions. Therefore, this user guide should be read and applied without fail by any person assigned to the installation and operating procedures of the product or system.

This user guide is part of the product, and the case may have to be passed to third parties or the following owners. It must be permanently kept at the usage site and be available for the operating personnel who are responsible for the installation of this product or system.

We are eager to ensure the comprehensiveness, relevance, and up-to-dateness of this user guide. It may become essential to make spontaneous changes to the product and its operation, which may not align with this manual, to maintain our technical advancement. In that case, Bacancy Systems PVT LTD will provide you with a new manual. We exclude liability for disturbances, failures, and resulting damages.

The illustrations in this user guide will provide a better understanding. It can occur that illustrations are not drawn to scale or deviate somewhat from the original.

### 1.2 Limitations of Liability

All statements and remarks in this user guide have been aggregated with consideration of current standards, laws, and regulations, the state of technology, as well as our extensive knowledge, long-time expertise, and experience. In special models, due to demands for additional order options or the latest technical alterations, the actual scope of delivery can differ from the explanations and elaborations described here.

The manufacturer excludes any liability for damages caused by:

- Inappropriate assembling and installation.
- Non-observance of the user manual.
- Non-intended and improper use.
- Use beyond operation limits.
- Deployment of insufficiently qualified and trained personnel.
- Use of unauthorised spare parts and accessories.

## 2. Safety

The safety directions, cautions, warnings, and notices are stated here. Moreover, in this user guide's section, the following sections have to be followed to reduce potential health risks and prevent hazardous situations as per the ISO 45001:2018 standard for occupational health and safety.

### 2.1 Safety Graphical Pictogram or Symbol

These prescribe safety signs for the purposes of accident prevention, fire protection, health hazard information, and emergency evacuation as per the ISO 7010:2019 standard for graphical symbols, safety colours, and registered safety signs.

The safety instructions are structured as follows:

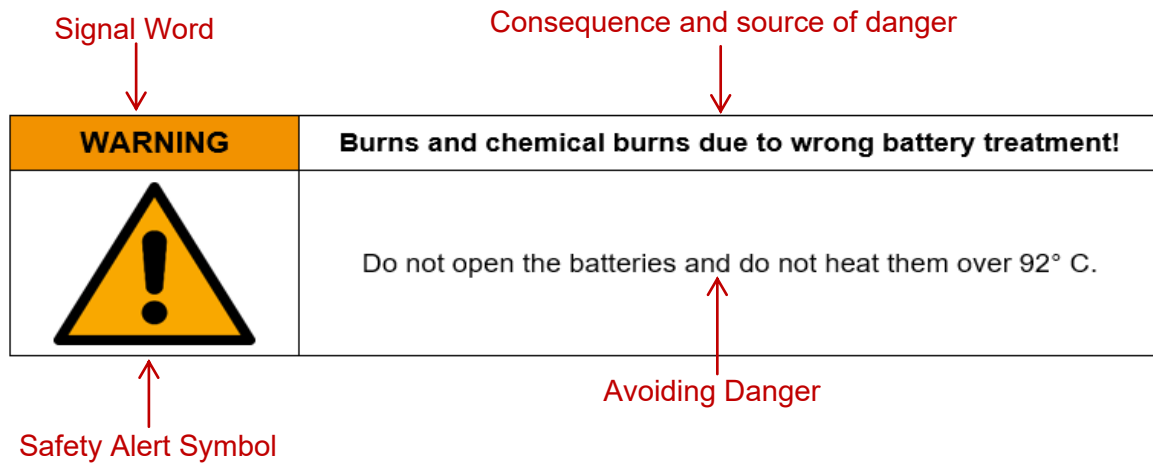











Figure 1 Safety Instruction

Table 1 Safety Graphical Pictogram or Symbol

Pictogram / Symbol	Signal Word	Meaning
	<b>DANGER!</b>	In case of non-compliance with this safety instruction, death or serious injury will occur.
	<b>WARNING!</b>	In case of non-compliance with this safety instruction, death or serious injury can occur.
	<b>CAUTION!</b>	In case of non-compliance with this safety instruction, a minor or moderate injury can occur.
	<b>NOTICE!</b>	In case of non-compliance with this safety instruction, material damage can occur.
	<b>NOTE!</b>	Useful notice or tip on the products or system's easy operation.

## 2.2 Safety Instruction and Warnings

<b>MANDATORY</b>	<b>Read User Guide</b>
	To get an understanding of the product, the user should pay careful attention to the user guide.
<b>PROHIBITION</b>	<b>Hot Works</b>
	Hot work shall be prohibited in close proximity to fully charged batteries. It will result in a battery explosion.
<b>CAUTION!</b>	<b>Working with Machine Tools Near the Battery</b>
	To prevent the occurrence of sparks, short circuits, or explosions, the user shall take precautions near the operation of a machine tool with a battery.
<b>PROHIBITION</b>	<b>Metallic Articles</b>
	Metallic articles such as watches, bracelets, rings, necklaces and others shall be wear prohibited during the installation, operation and maintenance.
<b>PROHIBITION</b>	<b>Installation Environment Circumstance</b>
	High concentrations of oxidising or salted gases, wet or dusty surfaces, proximity to sources of extreme heat, open flames, or sparks, or high variation with temperature, proximity to storage of highly flammable materials or gas concentrations, and proximity to areas unprotected from water or high humidity are all prohibited.
<b>MANDATORY</b>	<b>Special Insulated Tool</b>
	While installation, operation and maintenance the user shall be mandatory to use special insulated tools.

<b>MANDATORY</b>	<b>Installation and Maintenance</b>
	Installation and maintenance should be carried out under the supervision or advice of a qualified professional.

<b>PROHIBITION</b>	<b>Assembly and Disassembly</b>
	The assembly or disassembly of an open, repaired, default parameter, or changed production should be prohibited. The warranty could be void and invalid, and the service can be discontinued without notice. The use of a high-pressure washer to clean the product is prohibited.

<b>MANDATORY</b>	<b>Disconnect Power Supply</b>
	The power source or plug should be disconnected in the event of an unanticipated event or when conducting maintenance and repair.

<b>FIRE PROTECTION</b>	<b>Fire Extinguisher</b>
	In the event of a fire, the use of a dry powder fire extinguisher should be advised for fire control, and the use of water should be prohibited.

## 2.3 The Responsibility of Operator

The product is associated with industrial safety standards. However, the operator who is installing or operating the product is liable for the legal responsibilities for operational safety. In addition to the operational safety instructions in this manual, the safety, accident prevention, and environmental protection regulations valid for the operational area of the product shall be followed.

## 2.4 Person in Charge of Operations

<b>WARNING!</b>	<b>Risk of injury caused by lack of an adequate qualification!</b>
	Inappropriate handling of the product can lead to severe personal injuries and material damages.

In this manual the following qualification are specified:

<b>Instructed Person</b>	An instructed person is someone who has been instructed by the operator or manufacturer on the given tasks and potential hazards in the event of incorrect behaviour, as well as being semi-skilled and knowledgeable about the necessary safety procedures and safeguards.
<b>Qualified Specialised Professional</b>	Qualified specialised professionals are individuals who are knowledgeable with the assembly, commissioning, and operation of the product and process qualifications related to their work. The specialised individual is able to recognise hazards and prevent potential hazards because of their professional training, knowledge, and experience, as well as their understanding of the appropriate regulations.

## 2.5 In an occurrence of Danger or an Accident

Preventive Measures:

- Always be prepared for accidents or fires!
- Keep first-aid equipment (ambulance boxes, blankets, etc.) within easy reach.
- Inform personnel with accident alerting, first-aid, and emergency services.
- Keep clear access routes for emergency vehicles.

If the occurrence happens, follow these steps:

- Turn off the product immediately.
- Implement first-aid procedures.
- Get people out of hazardous areas.
- Inform the appropriate person at the usage spot.
- Contact a doctor and/or the fire department.

## 3. Packaging, Transport and Storage

### 3.1 Inspection Packaging and Transport

The products have been properly secured to ensure sufficient safeguarding during shipment. Please scrutinise the delivered products for overall quality and transportation problems as soon as possible.

**In the instance of external shipment damage, proceed as follows:**

- Do not accept delivery or accept it only on reserve.
- Issue a complaint.
- Do not use items that are obviously defective.

### 3.2 Transport

Always ensure that your equipment is transported in safe and appropriate containers while transporting it to the usage location or in the field.

Never transfer everything in an unplanned way in the vehicle. Hits and thrusts might seriously impair the product's functionality.

Always use the original packaging, transport containers, transport boxes, or equivalent packaging, whether transporting by train, aircraft, or ship. The container shields the goods from impacts and vibrations.

### 3.3 Storage

Strictly store the product in well-ventilated, dry spaces. During storage, keep it dry and leverage the original packaging if possible.

Avoid extreme heat fluctuations during storage. The initiation of water condensation can impair the product's operation.

When storing, keep in mind the temperature restrictions of the product. Please refer to the product's technical data for valid storage temperatures.

## 4. Intended Use

The purpose of this user guide is to give you basic information about the power module 40kW. This user guide is mainly focused on the technical aspects of the power module, which are covered in this user guide in graphical and tabular formats in various sections, as listed below:

Sections one to three featured information concerning the document and product's liability, safety, packing, transportation, and storage constraints. These first three parts will help you know how to follow pre-conception practises that must be followed before, during, and after utilising the product.

Section five contains technical information about the power module, such as its functions, features, applications, technical specifications, performance curve, and a block diagram of the module's internal architecture, including the communication protocol, interface, and functions. Describe how to set up and integrate the power module with additional components and mechanical dimensions to help users understand the installation.

Section six provides the information related to the installation of the power module, cable selection, connector position and size.

Section seven describes the power module's operating status, including the status and meaning of the LEDs and the information about the status displayed during use with the button.

Sections eight and nine describe the power module's operating environment and maintenance.

Finally, the appendix section included disposal of the product, abbreviation, and glossary, as well as the company's help desk and contact information.

<b>WARNING!</b>	<b>Risk caused by inappropriate use!</b>
	<p>Any unconventional use and/or different operation of the product can lead to hazardous situations.</p> <ul style="list-style-type: none"> <li>• Only use the product in a conventional manner.</li> </ul>

### 4.1 Limitation

The product is intended for use in an operational environment. It should not be used in hostile or explosive conditions.

The operator should consult local safety authorities and safety representatives before performing tasks in hazardous areas or in similar circumstances.

### 4.2 Alteration and Restoration of the Product/System

To prevent risks and make sure optimal performance, no alterations, attachments, or restoration of the product are permitted without explicit authorisation of Bacancy Systems PVT LTD.

## 5. Structure and Function



Figure 2 Power Module 40kW

The power module is a high-efficiency, high-power density AC/DC module specifically engineered by Bacancy Systems PVT LTD for fast charging applications for electric vehicles (EV). This module operates on a three-phase (3P+N+PE) and supports an input voltage range of 270 to 490 VAC. It delivers a rated output power of 40kW, with a constant power range from 300 to 500 VDC and 600-1000 VDC.

The charging module communicates with the main monitoring system via the CAN protocol to enable comprehensive parameter adjustments, operational data acquisition, and management of the module's functioning status. This connection ensures that the charging process is managed efficiently and precisely, improving the EV fast charging infrastructure's overall reliability and performance.

This advanced module is designed to meet the demanding requirements of modern EV fast charging stations, providing a robust and efficient solution for high-power charging applications.

- **Module Identification Nomenclature**

TH 40 F 10030 C 7 E-WT

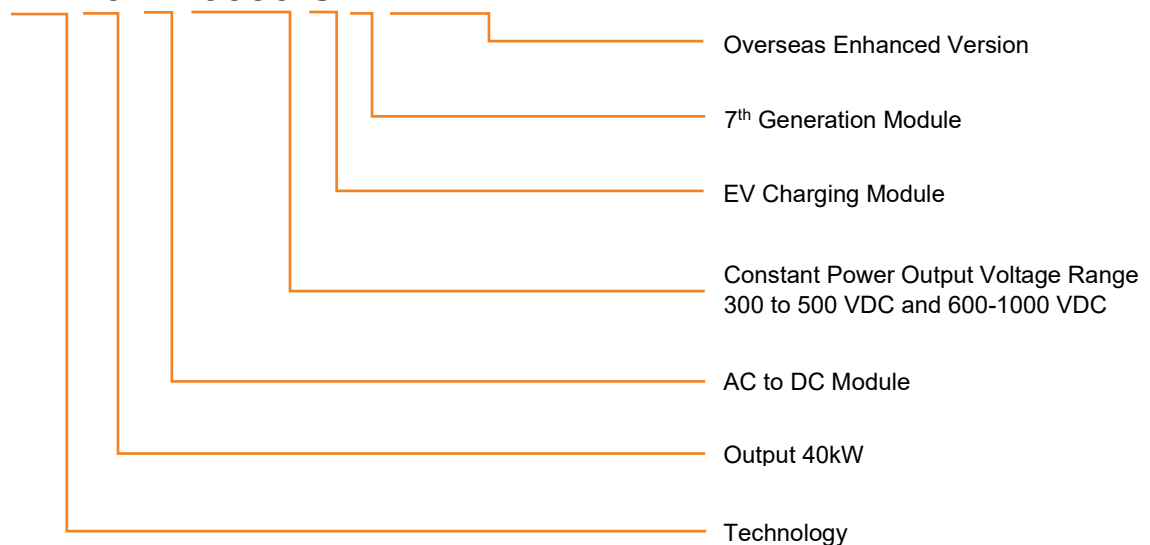

## 5.1 Overview

### 5.1.1 Feature

#### List of Feature

Digital technology, current sharing imbalance for modules parallel < $\pm 5\%$
Quick plug and install
Input and output power supply protection
Intelligent fan speed control
Support parallel voltage regulation and current regulation function
Ambient temperature detection and protection
Group current sharing function

### 5.1.2 Application

#### List of Applications

Fast Charging Station, On-board Charger and Battery Charger
---

## 5.2 Function

### 5.2.1 Technical Specification

#### Product Properties

Product Type	Power Module 40 kW
Product Family	Power Module

#### Input Electrical Properties

Nominal Voltage	380 VAC (3P+N+PE)	(Full power output: 360 to 467 VAC)
Working Voltage Range	270 to 490 VAC	
Maximum Current	67 A	(Effective Value)
Frequency Range	45 to 55 Hz	(Specified 50 Hz)
Power Factor	$\geq 0.99$	(30% to 100% Load)
Total Harmonic Distortion (THD)	$\leq 5\%$	(50% to 100% Load)
Standby Power Consumption	< 10 W	

#### Output Electrical Properties

Voltage Range	50 to 1000 VDC	
Maximum Output Current	134 A	
Current Range	0.5 to 100 A	
Constant Power Interval	300 to 500 VDC 600 to 1000 VDC	(Automatically switching between the high and low segments.)

#### Other Electrical Properties

Voltage Stabilisation Accuracy	$\leq \pm 0.5\%$	(The output voltage varies from 200-1000 VDC.)
Current Stabilisation Accuracy	$\leq \pm 1\%$	(From 20% of the rated output current to the maximum output current.)

Effective Value Coefficient of Output Ripple RMS	$\leq \pm 0.5\%$	(The output voltage ranges from 200 to 1000 VDC.)
Current Sharing Imbalance for Modules in Parallel	$\leq \pm 5\%$	(The Parallel average current should be more than 5A.)
Peak Efficiency	$\geq 96\%$	
Soft Start Time	3~8 s	
Output Anti-backflow	Yes	

### Module Protection Function

Input Over-Voltage Protection Point	$490 \pm 10$ VAC	(After the fault is shut down, the module is in standby mode after recovery.)
Input Over-Voltage Recovery Point	$475 \pm 10$ VAC	
Input Under-Voltage Protection Point	$270 \pm 10$ VAC	(After the fault is shut down, the module is in standby mode after recovery.)
Input Under-Voltage Recovery Point	$285 \pm 10$ VAC	
Input Phase Loss Protection	Yes	(If there is a missing phase, the module will be on standby after recovery, and the user needs to send a command to start it.)
Output Over-Voltage Protection	$1020 \pm 10$ VDC	(Equipped with hardware and software double overvoltage protection, the shutdown locked after the output overvoltage, and it needs to be powered on again to recover.)
Output Short-Circuit Protection	Yes	(Short circuit shut down and lock; after the short circuit is removed, it needs to be powered on again to restore the fault.)
Output Over-Current Protection	Yes	(After overcurrent shutdown, the module is in standby mode after recovery. The user needs to run a command to start the module.)
Fan Fault	Yes	(Shutdown due to failure, and the module is in standby after recovery and needs to send a command to start up.)
Emergency Stop Protection	Yes	(When there is an emergency stop signal input, the module shuts down without output voltage; after the emergency stop signal disappears, the module is in standby mode. The user needs to run a command to start the module.)

Internal Device Overtemperature Protection	Yes	(After over-temperature shutdown at 105°C, the module is in standby mode after recovery, and it needs to be started by issuing a command.) (Temperature compensation will be added inside the module according to different components to ensure reliable operation of the components. 105°C is the protection limit after compensation.)
Environment Over Temperature Protection	Yes	(Power output is limited above 50°C, and over-temperature shutdown above 75°C. For details, see <i>Figure 5</i> )
Temperature Difference Protection	Yes	(If the temperature difference between the same power unit is greater than 30 °C, the system shuts down. After recovery, the module is in standby mode.)

#### Communication

Protocol	CAN
----------	-----

#### Ambient Condition

Degree of Protection	IP20	
Operating Temperature	-40°C to 75°C	
Storage / Transport Temperature	-40°C to 75°C	
Relative Humidity	5 to 95 %	(Without condensation)
Noise	≤ 65 dB	(Support the upper computer to set the silent mode to less than 55 dB.) (Interval of more than 1m test)
Altitude	≤2000 m	(If the altitude exceeds 2000 m, the derating function is used. Manually set the altitude.)

#### Support

Prevent Current Rewinding

#### Mechanical Properties

Dimension (With connectors, without handles and raised front panel)	437.5 (L) X 300 (W) X 84 (H) mm	
Weight	≤ 16 kg	(Without packaging material)

#### Other

Insulation Resistance	Input to Enclosure Input to Output Output to Enclosure	(In a normal test environment, use 1000V insulation resistance test equipment with insulation resistance >500 MΩ.)
-----------------------	--	--

	Communication to Enclosure	(In a normal test environment, use 250V insulation resistance test equipment insulation resistance > 10 MΩ.)
Dielectric Strength	Input to Enclosure	(3500 VDC steady state leakage current < 10 mA for 1 minute No insulation breakdown or flashover occurs.)
	Output to Enclosure	
	Input to Output	(4200 VDC steady state leakage current < 10 mA for 1 minute No insulation breakdown or flashover occurs.)
	Communication to Enclosure	(1500 VDC steady state leakage current < 10 mA for 1 minute No insulation breakdown or flashover occurs.)

### 5.2.2 Performance Curve

#### A. Input Voltage Curve

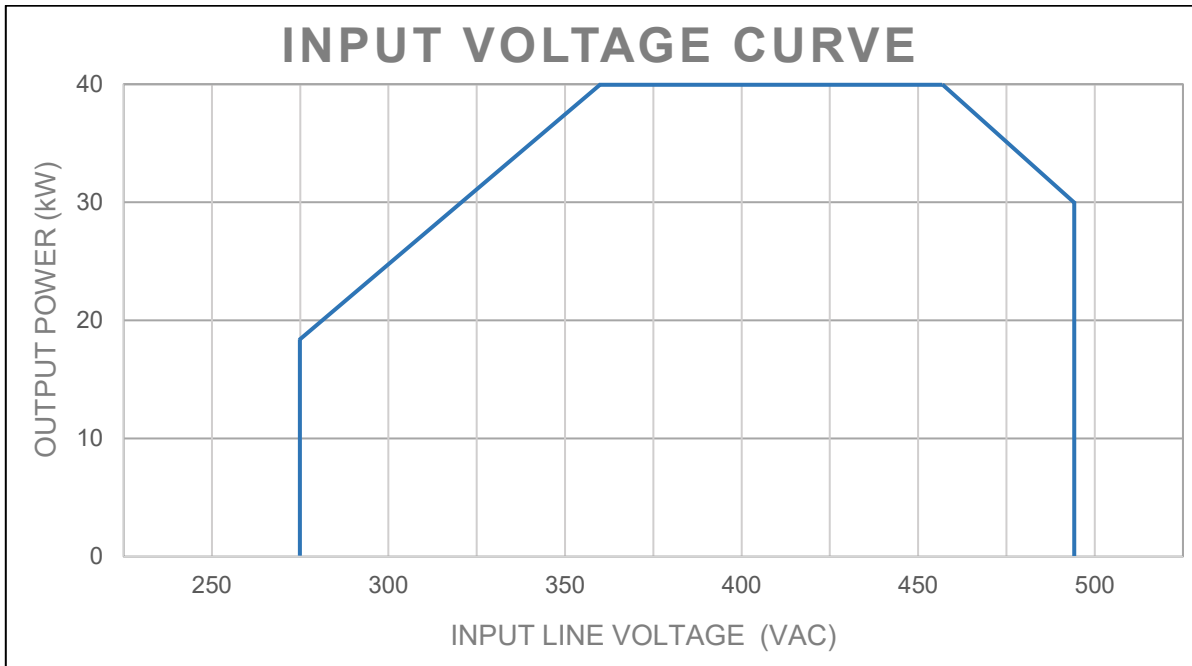

Figure 3 Input Voltage / Output Power Curve

#### B. Output Voltage Curve

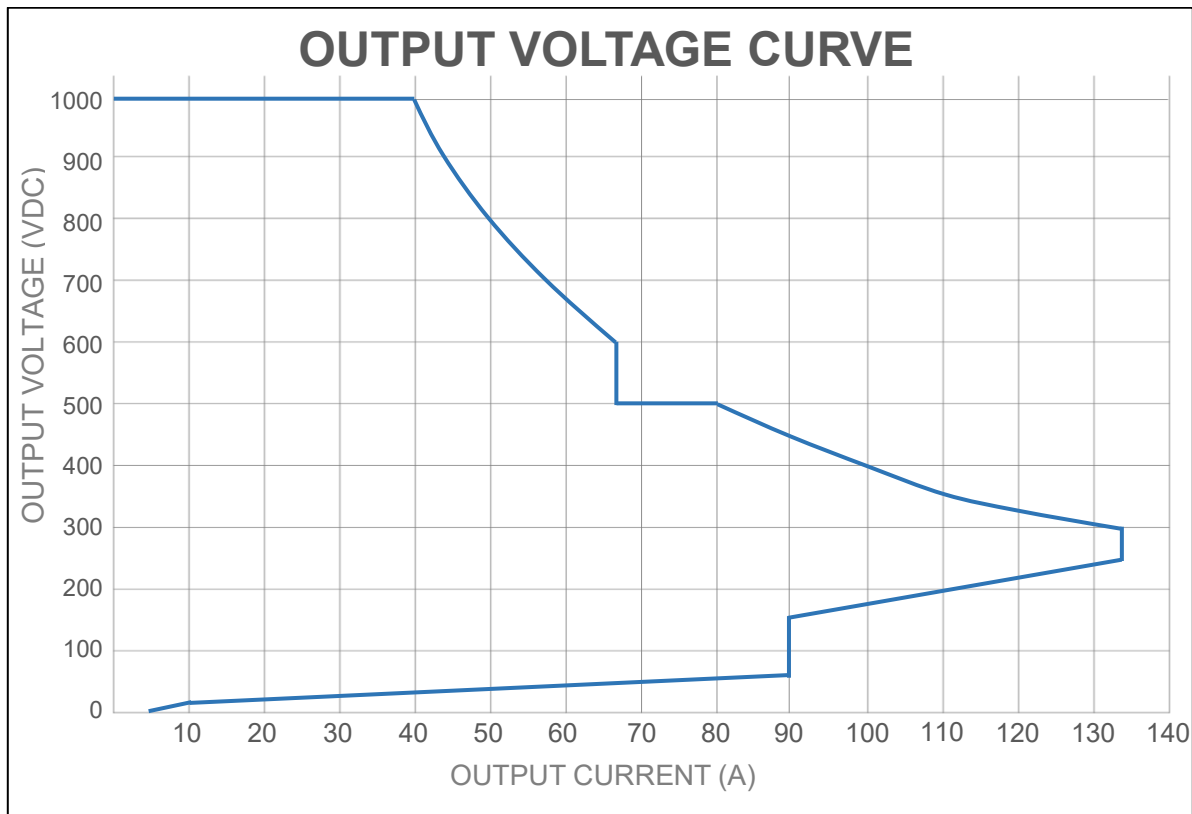

Figure 4 Output Voltage / Output Current Curve

**C. Environment Temperature Power Limit Curve**

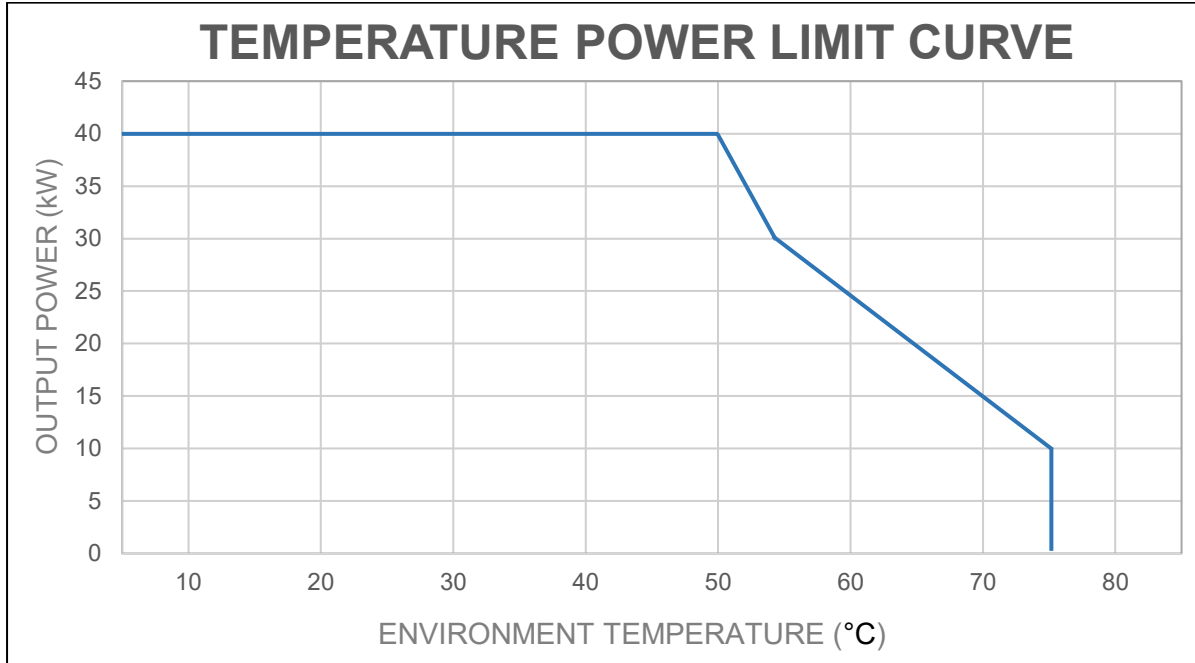
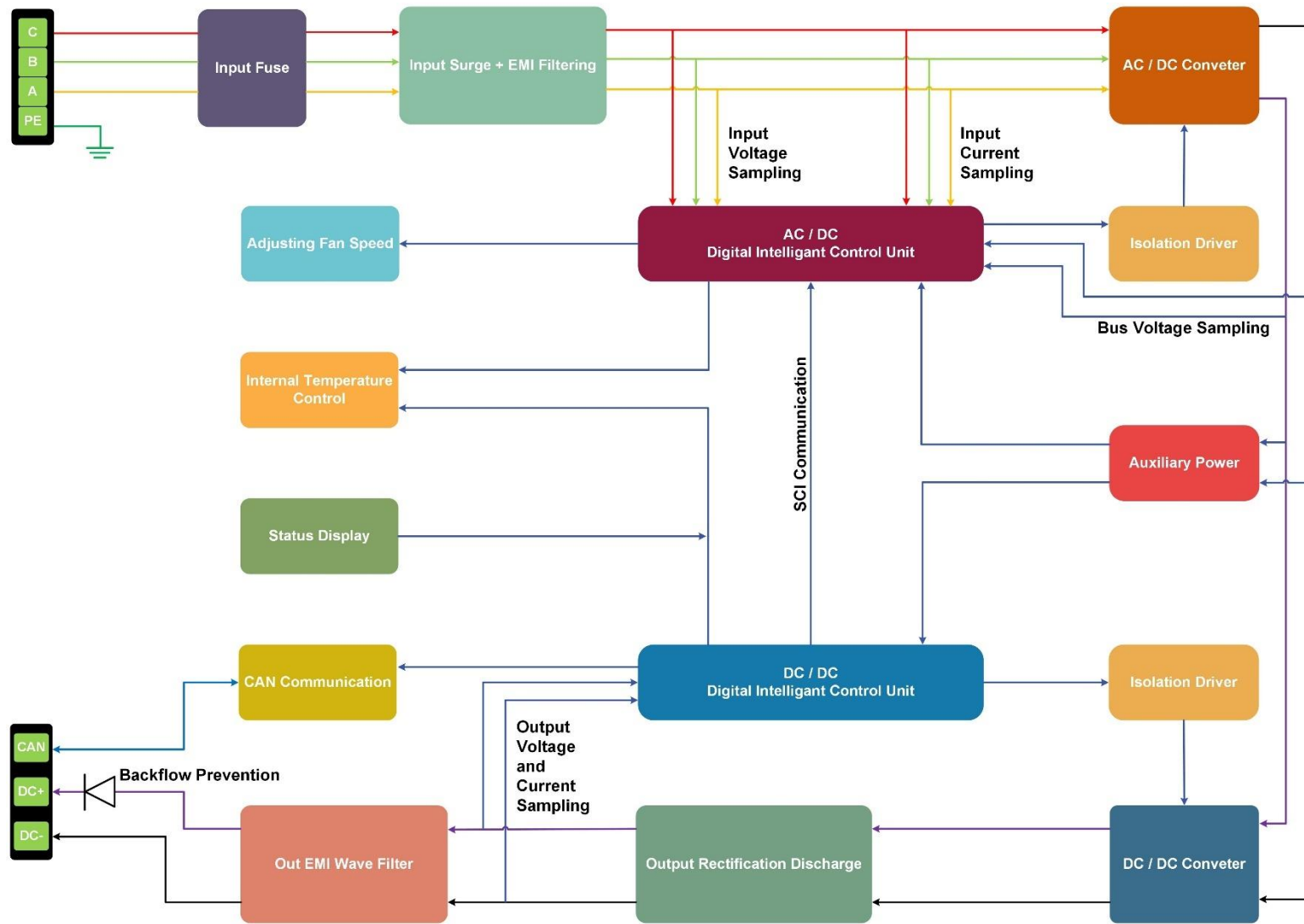
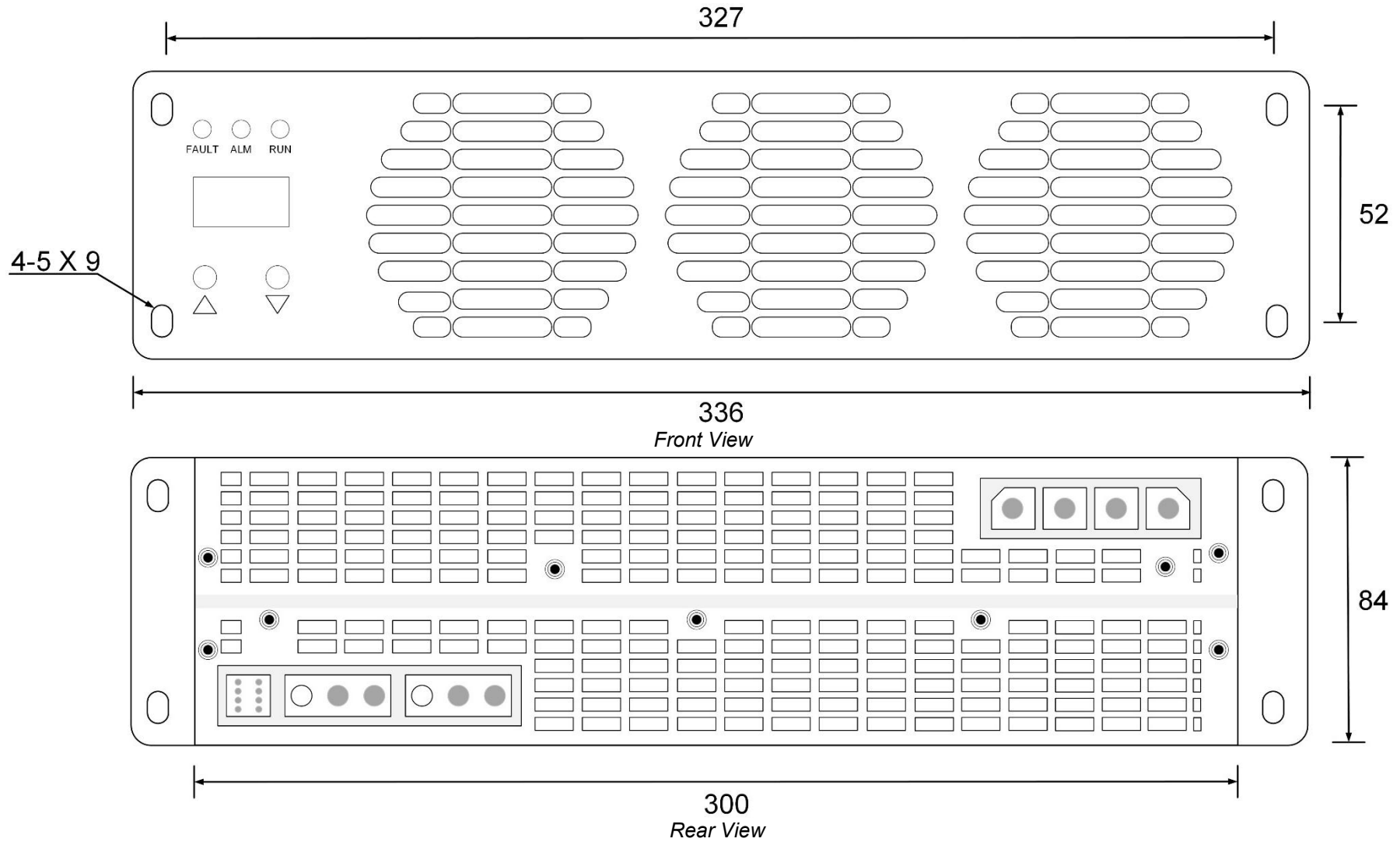

Figure 5 Output Power / Environment Temperature

5.2.3 Block Diagram



**5.2.4 Mechanical Diagram**



All dimensions are in mm.

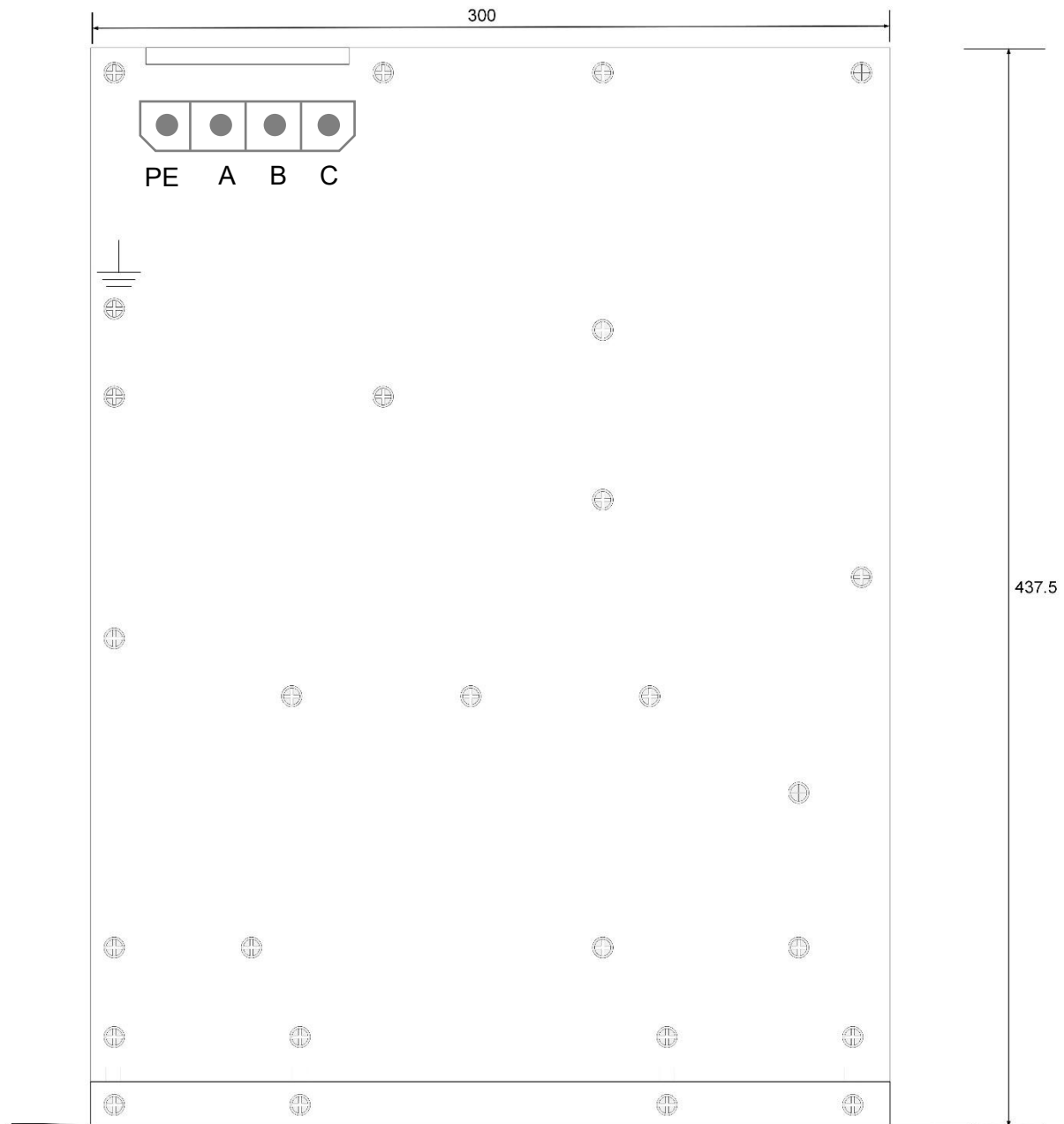

*Top View*

<b>NOTE!</b>	<b>Customise the Front Panel</b>
	<p>The user can contact Bacancy Systems to customise the front panel without adding handle and lock.</p>

## 5.2.5 Pin Configuration

### A. Input Connector

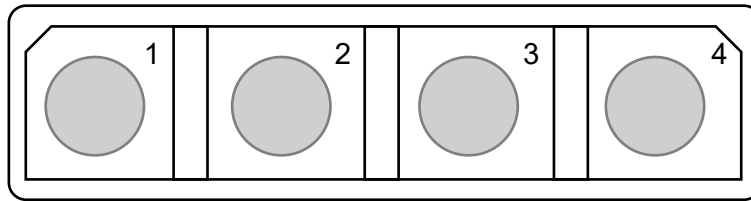

Figure 6 Input Connector

Table 2 Input Connector

Pin	Signal Name	Description
1	W	AC-C Phase Input Power Supply
2	V	AC-B Phase Input Power Supply
3	U	AC-A Phase Input Power Supply
4	PE	Input Earthing

### B. Output Connector

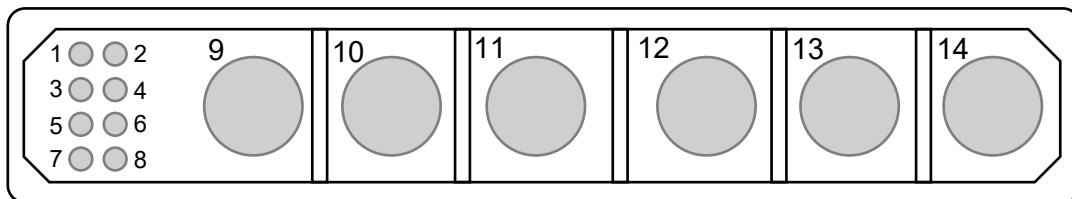

Figure 7 Output Connector

Table 3 Output Connector

Pin	Signal Name	Description
1	CAN H	CAN High Communication
2	CAN L	CAN Low Communication
3	Empty	-
4	Empty	-
5	Empty	-
6	Empty	-
7	Estop +	Emergency Stop Input Signal Positive
8	Estop -	Emergency Stop Input Signal Negative
9	Empty	-
10	Output Negative	Output Negative Power Supply
11	Output Negative	Output Negative Power Supply
12	Empty	-
13	Output Positive	Output Positive Power Supply
14	Output Positive	Output Positive Power Supply

### C. Extension of Output Connector

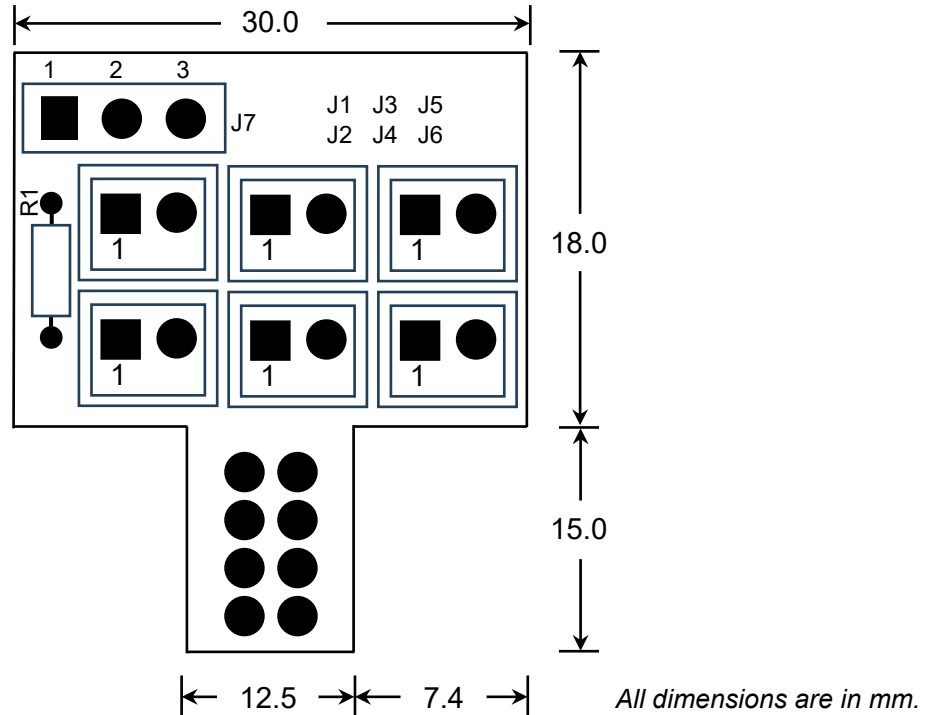



Figure 8 Extension of Output Connector

Table 4 Extension of Output Connector

Pin	Signal Name	Description
J1-1	CAN L	CAN Low Communication
J1-2	CAN H	CAN High Communication
J2-1	CAN L	CAN Low Communication
J2-2	CAN H	CAN High Communication
J3-1	ESTOP+	Emergency Stop Input Signal Positive
J3-2	ESTOP-	Emergency Stop Input Signal Negative
J4-1	ESTOP+	Emergency Stop Input Signal Positive
J4-2	ESTOP-	Emergency Stop Input Signal Negative
J5	Reserve	-
J6	Reserve	-
J7	Jumper Terminal	<ul style="list-style-type: none"> <li>1 &amp; 2 Short Circuit, Matching Resistance Access</li> <li>2 &amp; 3 Short Circuit, Matching Resistance not Access</li> </ul>

MANDATORY	Power Module Installation Position
	While installation, operation, and maintenance, the user shall be required to install the power module in a horizontal position.

## 6. Installation

### 6.1 Module

The instructions below describe how to install a power module.

1. With both hands, place the power module into the appropriate location in the cabinet.
2. Gently put the power module into its appropriate position, to ensure the connector is properly connected.
3. Tighten the two screws holding the power module's front panel to the cabinet.

### 6.2 Connector

When determining the aperture size of the power module terminal mounting panel, consideration should be given to assembly errors to the power module side terminals as well as machining errors to the power module itself, with a specific tolerance incorporated into the design.

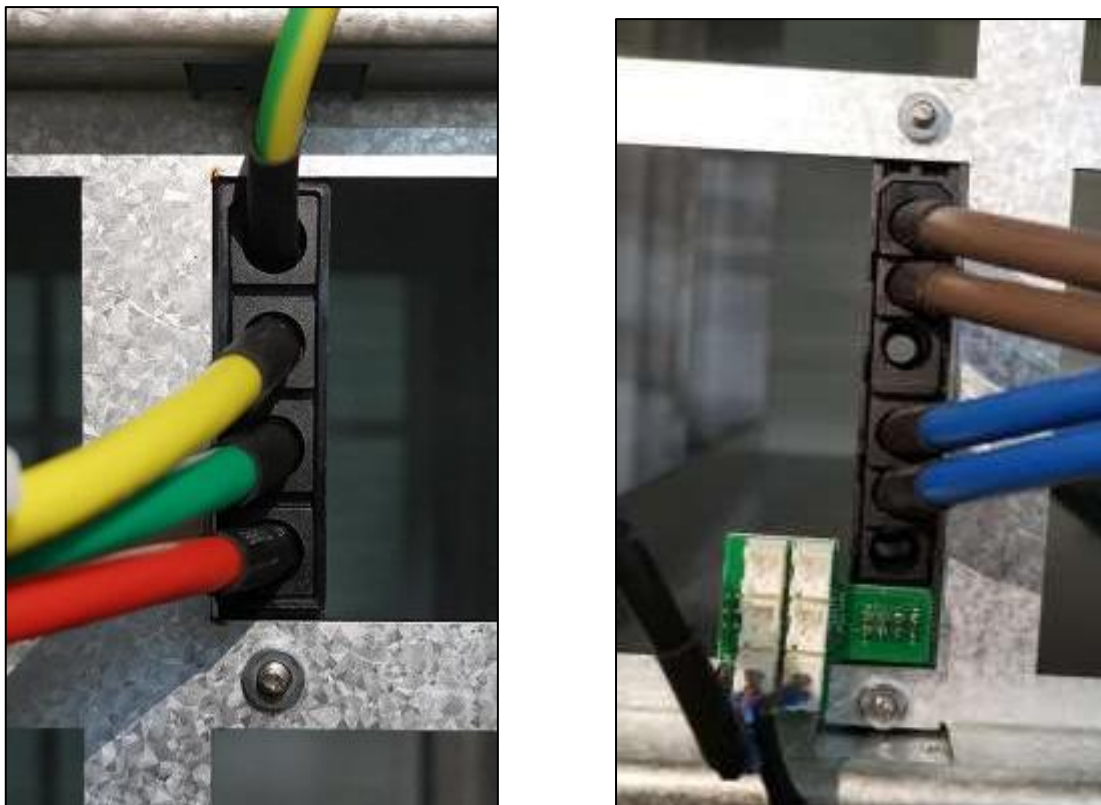

*Figure 9 The Connector of Power Module Installation.*

### 6.2.1 Connector Position and Size

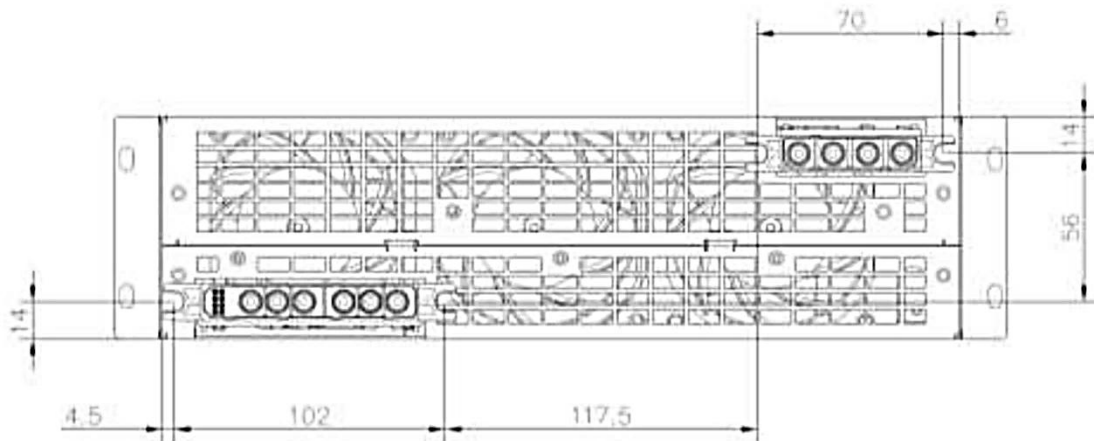

Figure 10 Connector Position and Size.

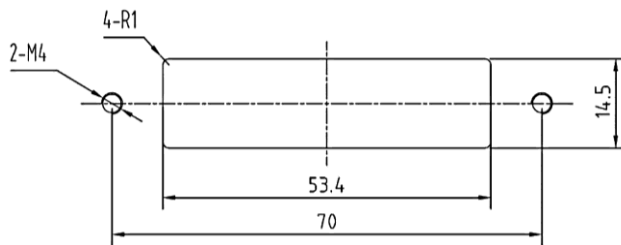

Figure 12 AC Input Connector Size.

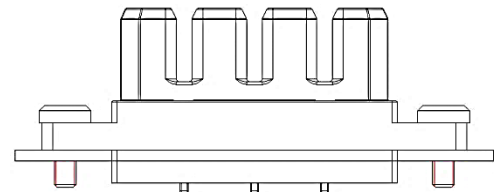

Figure 11 Reference Diagram:  
AC Input Connector.

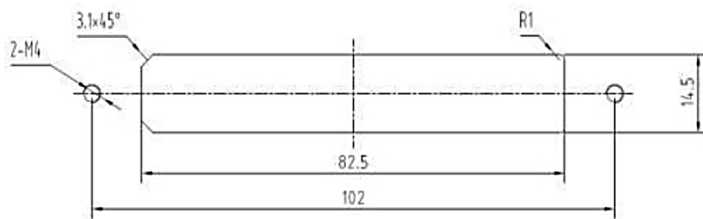

Figure 14 DC Input Connector Size.

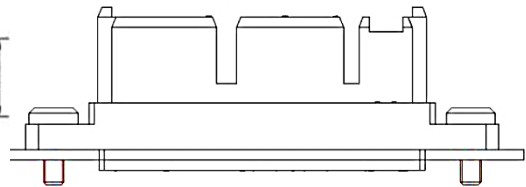

Figure 13 Reference Diagram:  
DC Input Connector.

All dimensions are in "mm".

The connecting terminals should be put on the inside side of the subframe sheet metal, with the screws fastened from the inside out. To prevent inappropriate installation of the power module and poor connection contacts due to interference with the chassis, use installation screws with a thread length of < 4mm.

### 6.3 Cable Selection

The specifications of the charging station's essential electrical components must be developed in accordance with the power module standards. At the same time, future power demand of the charging station should be addressed. Compatibility should be addressed while selecting devices, cables, and copper bus flow. Leaving apart the necessary power and structural interface, the primary elements influencing the specifications of important electrical components in the charging module are as follows:

1. The AC input cable is considered based on the maximum input current. (When the AC input line voltage reaches the minimum voltage of the full power output of the power module, the current becomes the maximum input current at the time.)
2. The DC output cable is considered based on the power module's maximum output current.
3. Shielded cables are suitable for communication purposes.
4. The wire harness is cold pressed. It is advised to use six-sided crimping pliers for the crimp tool. Single-sided crimping is not permitted, as it could damage the crimping hole.

Table 5 Type and Specification for Cable.

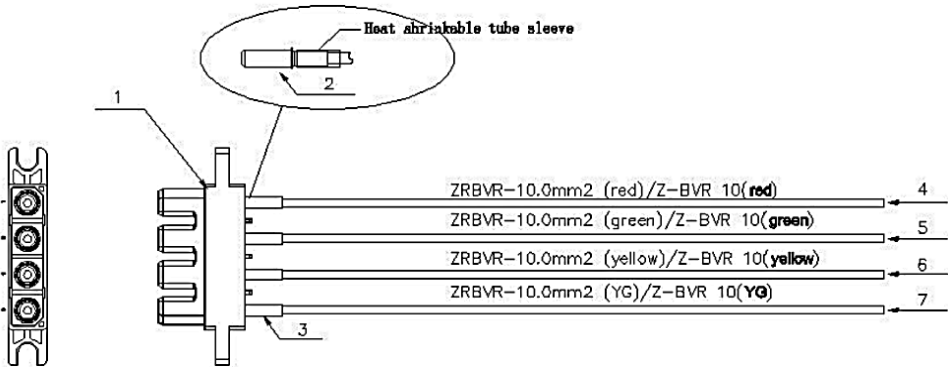
Type	Specification		
AC Input Power Line			
	No.	Model	Quantity
	1	Connector Socket	1
	2	5 hole Pressing	4
	3	25 mm 8 Black Heat Shrink Tube	4
	4	ZRBVR-10.0mm <sup>2</sup> (Red) / Z-BVR 10 (Red)	1
	5	ZRBVR-10.0mm <sup>2</sup> (Green) / Z-BVR 10 (Green)	1
	6	ZRBVR-10.0mm <sup>2</sup> (Yellow) / Z-BVR 10 (Yellow)	1
7	ZRBVR-10.0mm <sup>2</sup> (Y-G) / Z-BVR 10 (Y-G)	1	

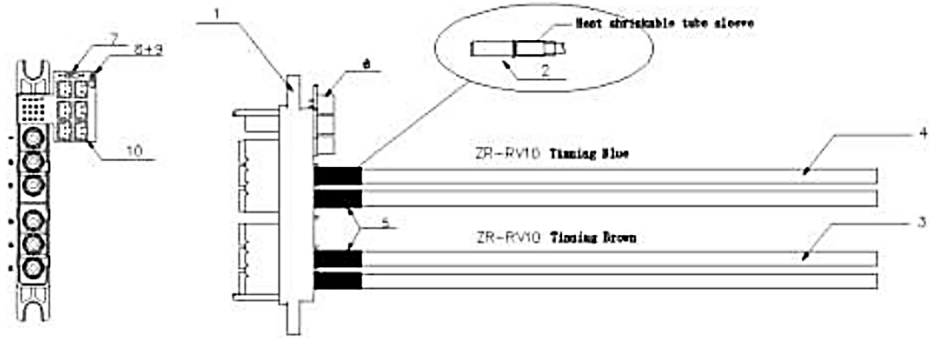
 DC Output  
 Power Line

No.	Model	Quantity
1	Connector Socket	1
2	Ø5 Hole Pressing	4
3	ZR-RV10 Tinning Brown	2
4	ZR-RV10 Tinning Blue	2
5	25mm Ø8 Black Heat Shrink Tube	4
3	TH30F10025C7-2-ZJBX10 1.0 Adaptor Plate	1
7	Metal Film Resistance RJ14-1/4W-120ΩF	1
8	Single Row Straight Pin Seat 2.54 1*3P L=11.6	1
9	Short-Circuit Connector 2.54-2	1
10	Connector Seat TJC3-2A	6

 CAN  
 Communication  
 Line

 0.3 mm<sup>2</sup> (22AWG) twisted-pair shielded flame-retardant cable with a voltage resistance of 60VDC and a temperature range of -40°C to 105°C.

Crimp Tool



## 7. Operating Status

### 7.1 Power Module Panel

There are buttons, digital tube and indicator lights on the panel of the power module.

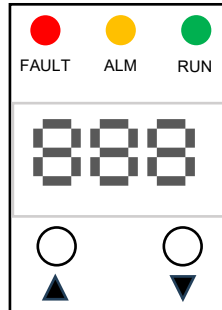

Figure 15 Power Module Panel.

### 7.2 Button

To configure the power module, use the two up and down buttons to alter the display content and adjust the set value.

Table 6 Navigation Button.

No.	Function	Press	Button	Description
1	Parameter Switch	Short Press	▲ or ▼	To get parameter-related information in succession.
2	Setting Menu	Press Hold (2.5 S)	▲ or ▼	Enter the settings menu.
3	Setting Parameter	Short Press	▲ or ▼	To increase and decrease setting parameters.
4	Parameter Value	Press Hold (2.5 S)	▲	To change the parameter value digit (one/ten/hundred).
5	Save Present Setting	Press Hold (2.5 S)	▼	To save the current setting up parameters and proceed to the display page.

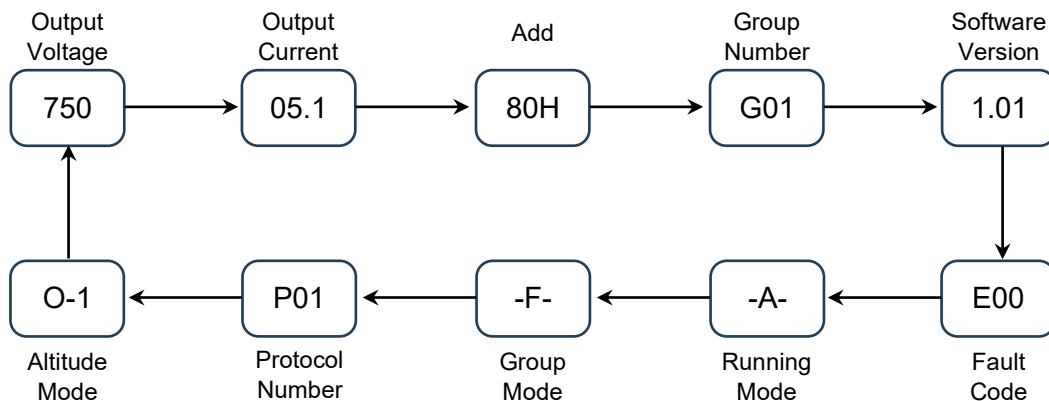

Figure 16 Information Display Flow.

Table 7 Operation Buttons.



No.	Function	Press	Button	Description	
1	View Information	Short Press	▲ or ▼	To view module information.	
2	Display Page	Short Press	▲ or ▼	To switch displayed pages in the sequence.	
		Press Hold (2.5 S) The interface starts to blink	▲ or ▼	To enter the setting screen from the display screen.	
3	Set Interface	Short Press	▲ or ▼	To increase or decrease the setting parameter.	
		Press Hold (2.5 S) The interface blinking position changes	▲	To modify the parameter value digit (One, Ten, or Hundred).	
		Press Hold (2.5 S)	▼	To save the present setting parameter and move forward to the display page.	
4	Address Setting	<b>Using 80H to replace 91H as an example:</b>			
		1	Press Hold (2.5 S)	▲ or ▼	The interface appears for 80H or The interface flashes ("0").
		2	Short Press	▲	80H to change in 81H
		3	Press Hold (2.5 S)	▲	The interface "8" flashed.
		4	Short Press	▲	Set address values from 81H to 91H.
		5	Press Hold (2.5 S)	▼	To save the present setting parameter and move forward to the display page.
5	Operation Mode Setting	1	Enter the setting interface and the data saving.	<ul style="list-style-type: none"> <li>• <b>Automatic Mode:</b> The upper computer control module starts and stops.</li> <li>• <b>Debugging Mode:</b> The module starts up automatically, which is convenient to confirm the status of the module on site.</li> </ul>	
		2	Automatic Mode: -A-		
		3	Debug Mode: -C-		
6	Group Mode Setting	1	Enter the setting interface, and the data saving	Modify the module grouping mode and save the parameter after power off.	
		2	Fixed Packet Mode: -F-		
		3	Dynamic Packet Mode: -d-		

7	Protocols setting	1	State grid agreement: P01	Switchable Communication Protocol.	
		2	Bacancy Agreement: P02		
8	Elevation Mode	1	Normal Altitude Mode: o-1 (Altitude within 2000 m)	Different application scenarios at different altitudes.	
		2	High Altitude Mode: o-2 to 0-8 (Altitude between 2000m and 5500 m)		
9	Parameter Settings in Debug Mode	<b>Voltage and current parameters can be set.</b>			
		1	Press Hold (2.5 S)	▲ or ▼	The interface 500 appears. or The interface flashes in one bit.
		2	Press Hold (2.5 S)	▲	The interface 10 flashes.
		2.1	Short Press	▲	Change 500 to 550.
		2.2	Press Hold (2.5 S)	▲	The interface 100 flashing.
		2.3	Short Press	▲	Change 550 to 650.
		3	Press Hold (2.5 S)	▼	Save the current setting parameter and go to the display page.

### 7.3 Indicator LED Light



The indicator LED light is fully used to represent the functioning and fault status of the power module, which operates in three basic states: extinguished, always on, and flashing, with the arrangement and combination of the three indicators producing 27 states. There are several meanings for this, making it difficult to create a single specification that clarifies the exact meaning of each indication LED light.

Table 8 Definition of Indicator LED Light

No.	LED Colour	Description
1	Green 	To indicate the running state.
2	Yellow 	To indicate alarm information. (Not serious in nature and often caused by improper operation or environment factors.)
3	Red 	To indicate fault information. (When such problems occur, it usually leads to shut down. It is often a self-protection that exceeds the normal working limit of the module. Continued operation may cause irreversible damage to the module.)

#### A. State Grid Protocol Indicator

Table 9 Definition of State Grid Protocol Indicator

No.	Function	Description
1	Running Lights	<ul style="list-style-type: none"> <li>• Colour (): Green.</li> <li>• Always OFF: NOAC input.</li> <li>• Steady ON: There is an AC input, and the status is normal.</li> </ul>
2	Protection Light	<ul style="list-style-type: none"> <li>• Colour (): Yellow.</li> <li>• Always OFF: In the normal state, the charging module does not have a protective alarm.</li> <li>• Steady ON: Possible issues include input overvoltage, undervoltage, phase loss, overheating in the environment, and address duplication.</li> <li>• 0.5 Flickering: The communication between the module and the host computer is interrupted.</li> </ul>
3	Fault Indicator	Colour (  ): Red Always OFF: In the normal state, the charging module is not faulty. Steady ON: Possible issues include output over-voltage, short circuit, fan failure, discharge failure, internal module over-heating, communication disruption, and non-recoverable non-output crashes.





## B. Bacancy Agreement Indicator



Table 10 Definition of Bacancy Agreement Indicator

No.	Function	Description
1	Steady Red Light	Input Abnormality (Overvoltage, Undervoltage, Phase Loss).
		Abnormal Busbar (Overvoltage, Undervoltage).
		Sci Communication (Abnormal communication of front and rear stage SCI).
		Output Overvoltage (Hardware Overvoltage, Software Overvoltage).
		PFC Abnormality (Pre-Stage Failure Shutdown).
		Fan Failure.
		Internal Overheating.
		Output Short Circuit.
		Bleed Failure.
		Bus Bais.
Address Conflict.		
2	Solid Yellow Light Green Light	Output Undervoltage Warning.
		Output Overvoltage Warning.
3	Yellow Light Flashes, Green Light Stays On	Limited Power.
4	Green Light Flashing	Module Standby Without Failure.
5	Green Light	The Module Is Running Normally.
6	Red Light Yellow Light	CAN Communication Interrupted.

## 8. Operating Environment

The power module is designed according to IP20 protection level, and the heat dissipation method is active air cooling. For typical usage, environmental conditions, stack protection design and system heat dissipation design need to be addressed.

<b>PROHIBITION</b>	<b>Installation Environment Circumstance</b>
	The product should not be installed near liquids, and it should not be installed under water-proof locations such as air conditioners, vents, or outlet windows in the equipment room to prevent liquids from entering the device and causing short circuits, as well as to ensure that there is no condensation near power module.
<b>MANDATORY</b>	<b>Outdoor Protection</b>
	In general, the level of outdoor protection should be greater than IP54.
<b>PROHIBITION</b>	<b>Marine Environment, Pollution, Heavy Industries, and Mining</b>
	<p>Prohibits the use of the product in the maritime environment or on outdoor area near a pollution source or in an area with only minimal sheltering.</p> <p>However, if the user intends to use the charging pile in the environment, the protection level should be greater than IP65, otherwise the product will malfunction. The sources of pollution include the following:</p> <ul style="list-style-type: none"> <li>• 4 km radius from high salt content (such as the ocean)</li> <li>• 3 km away from severe pollution sources such metallurgy, coal mining, thermal power plants, chemicals, rubber, and electroplating.</li> <li>• 1 km away from low pollution sources such as food, leather, and heating burners.</li> </ul>
<b>PROHIBITION</b>	<b>Corrosive and Insulating Environment</b>
	<p>The use of the product is restricted in corrosive and insulating environments.</p> <p>However, if the user intends to use the charging pile in the environment, the protection level should be greater than IP65, otherwise the product will malfunction.</p>

<b>MANDATORY</b>	<b>Altitude Level</b>
	The product shall be used within 2000 meters of altitude.
<b>PROHIBITION</b>	<b>Risk of Fire / Flammable Materials</b>
	Please avoid installing and using this equipment in places such as gas stations, gas stations, etc. that have safety and explosion-proof requirements for electrical equipment.

### A. Heat Dissipation

The power module uses a DC axial fan to disperse heat. The power module uses a fan speed regulation approach to precisely change the fan speed, resulting in low temperatures and noise. Furthermore, the fan-induced power module loss can be decreased.

The heat dissipation of the charging station system can be designed based on factors such as the air volume and ambient temperature of the power module to reduce system power consumption and noise. For more information on the heat dissipation of the power module.

- **Fan Characteristics**

Parameter (25°C)	Value
Air Volume (under zero static pressure)	120 CFM (3.4 m <sup>3</sup> /min)
Wind Pressure (at zero air volume)	3.21 inch-H <sub>2</sub> O (81.54 mm-H <sub>2</sub> O)

- **Air Volume required**

Parameter	Value
Power	40kW
Number of Fans	3
Minimum Air Volume Requirement	360 CFM
Increase Air Demand	420 CFM

The data above only represents the air volume requirements of a single power module. The ventilation volume of the system is estimated based on the total number of modules, excluding the air volume required by other devices.

**Explanation:**

1. The ambient temperature of the power module refers to the temperature at the air inlet of the fan.
2. The information is evaluated for a single power module with an air inlet and outlet which are not covered. The effect of system resistance on the functioning point of module fans should be addressed during system design.

• **PQ Curve of the Fan Used by the Power Module**

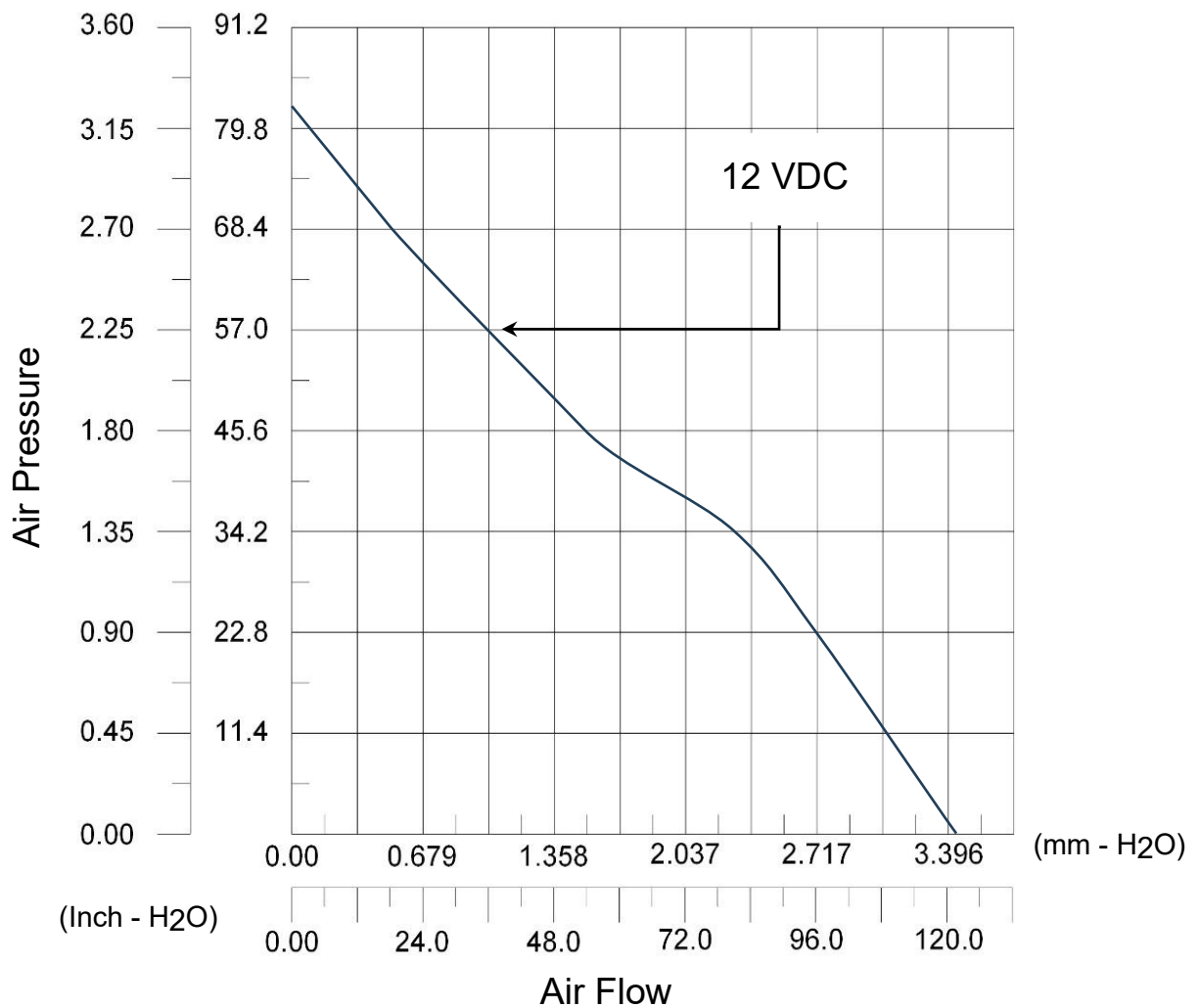

## B. Reference Design for Heat Dissipation of Power Module

**Anti-Hot Air Reflux Design:** Hot air reflux occurs when all or a portion of the high-temperature air release from the power module's outlet is redirected to the power module's intake. As a result, the temperature at the inlet rises abnormally, interfering with the normal functioning of the power module. A typical backflow prevention design can be referred to as follows:

### 1. Cut off the hot air return channel

- Isolate hot and cold air from the power module's air inlet and outlet and close the hot air return channel. To avoid return air, install filler panels in the reserved places of the power module. To prevent air return between the power module and the installation place, use seals or sealing plates.

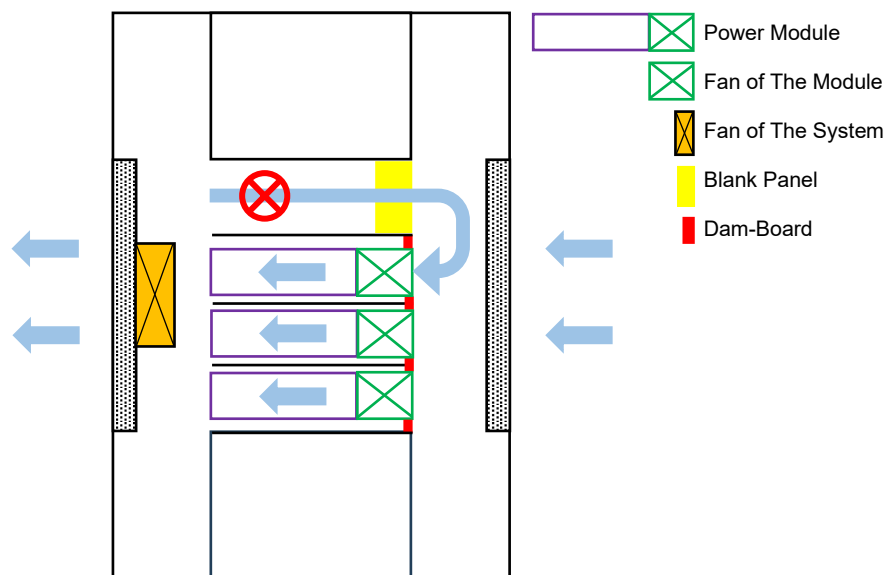

### 2. Air Volume Matching

- The total of the air volume at the operating point of all system fans should be more than the air volume required by the power module's hot air to avoid hot air accumulation caused by insufficient air exhaust capacity.
- Due to system resistance (such as blinds and air filters), the air volume at the operating position of the system fan is less than the maximum air volume stated in the fan specification.
- When selecting a system fan, the total maximum air volume indicated in the system fan specification must be 1.5 to 2 times the power module pile's hot air exhaust volume.
- Determine the operating point of the system fan using the fan PQ curve and the system resistance curve, and make sure that the total of the fan operating point air volume exceeds the power module pile's hot air exhaust volume.

### 3. Suggestions for Inlet and Outlet

- Because the working point of the power module fan is impacted by inlet and outlet air resistance, the user should charge the power module to guarantee smooth inlet and outlet air resistance.
- The inlet and outlet air resistance impact the power module's fan's working condition. The power module should be kept at a particular distance from the air intake and air exit to guarantee smooth operation.
- The distance between the power module and the air inlet must be at least 50 mm, and the module must be at least 100 mm from the air exit.
- The ventilation area of a single power module should be extended to 20000 mm<sup>2</sup>, with a minimum of 15000 mm<sup>2</sup>.
- The ventilation area of the charging station is computed by adding the number of power modules.

## 9. Maintenance

The maintenance instructions are provided here. Furthermore, in this user guide, the following sections must be followed to operate the power module efficiently and effectively.

MANDATORY	<b>Disconnect Power Supply</b>
	<p>The power source or plug should be disconnected in the event of an unanticipated event or when conducting maintenance and repair.</p>

1. The dustproof net of the cabinet should be cleaned and dedusted on periodic intervals to reduce dust accumulation in the air intake, which causes excessive temperatures within the module.
2. If the power module is in unrecoverable fault circumstances, replace it immediately.

### 9.1 Preventive Instruction

1. Periodically clean and dust the air filter of the cabinet to prevent dust from collecting in the air inlet, which may cause high temperatures inside the module, power limits, or even damage to the power module.
2. To ensure proper grounding, check the power module and the entire power module pile on a regular basis.
3. Check the operation of the power module fan and the system fans on a regular basis.
4. Check the rain protection on a regular basis to prevent rainwater from reaching the charging station's body.

### 9.2 Replacement

1. Disconnect the AC input circuit breaker from the malfunctioning power module and unscrew the screws on the front panel.
2. Hold the module handle with one hand and the power module body with the other hand and pull the power module out of the cabinet slowly.

CAUTION!	<b>Burn</b>
MANDATORY	<b>Wear Protective Gloves</b>
	<p>The surface of the power module may be hot; use protective gloves to avoid the burn.</p>

3. To replace the power module, follow the installation instructions (Section 6).
4. Turn on the AC input circuit breaker for the power module.
5. Check that the monitoring module can recognize the newly replaced power module (State Grid Protocol needs manual address configuration) and that the new power module flows in the same way as the previous power modules.
6. If every components are normal, it means that the process went smoothly, and the replacement is completed.

## 10. Appendix

### 10.1 Dispose of Product

Disposal	Product Disposal and Recycling
	<p>Out-of-service products should be handed over to the recycling industry, dealers, or manufacturers.</p>

### 10.2 Abbreviations and Glossary

°C	<i>The degree Celsius (symbol: °C) can refer to a specific point on the Celsius temperature scale or to a difference or range between two temperatures.</i>
3P+N+PE	<i>A 3-phase 4-wire + PE system is an electrical power distribution system that consists of three conductors carrying alternating current (AC) power, a neutral conductor, and a protective earth conductor.</i>
A	<i>An ampere is a unit of measure of the rate of electron flow or current in an electrical conductor.</i>
AC	<i>Alternating current, is a type of electrical current in which the current repeatedly changes direction.</i>
ALM	<i>Alarm</i>
CAN	<i>A controller area network (CAN) bus is a high-integrity serial bus system for networking intelligent devices. CAN busses and devices are common components in automotive and industrial systems.</i>
dB	<i>Decibel (dB), a unit for expressing the ratio between two physical quantities, usually amounts of acoustic or electric power, or for measuring the relative loudness of sounds. One decibel (0.1 bel) equals 10 times the common logarithm of the power ratio.</i>
DC	<i>Direct current (DC) is one-directional flow of electric charge.</i>
EV	<i>An EV is defined as a vehicle that can be powered by an electric motor that draws electricity from a battery and is capable of being charged from an external source.</i>
Hz	<i>hertz, the SI unit of frequency, is equal to one cycle per second.</i>
IP	<i>Ingress Protection (IP) ratings, which grade the resistance of an enclosure against the intrusion of dust or liquids.</i>

<i>kg</i>	<i>A unit of measurement of weight equal to 1000 grams.</i>
<i>kW</i>	<i>kW is a kilowatt. kW is used to represent the actual power that carries out the work.</i>
<i>LED</i>	<i>A light-emitting diode (LED) is a semiconductor device that emits light when current flows through it.</i>
<i>m</i>	<i>A meter (m) is the International System of Units (SI) unit of length.</i>
<i>mA</i>	<i>A milliampere (also milliamp or mA) is 1/1000 of an Ampere.</i>
<i>mm</i>	<i>The millimetre is a unit of length in the International System of Units (SI), equal to one thousandth of a metre.</i>
<i>MΩ</i>	<i>Symbol for megaohm, an SI unit of electrical resistance equal to 10<sup>6</sup> ohms</i>
<i>PE</i>	<i>A protective earth connection, earth ground, or safety ground uses a protective conductor to safely direct a fault current into the earth and away from a human being in contact.</i>
<i>s</i>	<i>The second (symbol: s) is the unit of time.</i>
<i>V</i>	<i>Voltage, also known as (electrical) potential difference, electric pressure, or electric tension is the difference in electric potential between two points.</i>
<i>VAC</i>	<i>VAC (Volts Alternating Current) is a measure of the strength of the alternating electric field that drives the flow of electrons in AC electrical systems.</i>
<i>VDC</i>	<i>VDC refers to volts of direct current, and it can come from either a battery or a power supply that converts AC (alternating current) into DC.</i>
<i>Ω</i>	<i>A unit of electric resistance equal to the resistance of a circuit in which a potential difference of one volt produces a current of one ampere.</i>

 **Bacancy Systems PVT LTD,**  
15-16, Times Corporate Park,  
Near, Thaltej-Shilaj Road,  
Opp. Copper Stone Flats, Thaltej  
Ahmedabad, Gujarat,  
India, 380059

 [www.bacancysystems.com](http://www.bacancysystems.com)

 [systems@bacancysystems.com](mailto:systems@bacancysystems.com)

 +91 90160 28817

 **Helpdesk:** <https://bacancy.freshdesk.com/a/dashboard/default>