

User Guide

Bharat DC001 Master Controller

Please completely read this document and the contained safety instructions and note all given information before usage.

Please maintain the confidentiality of this user guide. It is intended solely for usage by people professionally associated with the product. If you are not the intended recipient, you may not disclose or use the information in this documentation. The information does not constitute an offer or solicitation to buy or sale of any security.

This user guide's text and illustrations have been meticulously crafted. However, we may not be held accountable for any discrepancies or failure consequences.

Some company and label names are protected by a label, a patent, or a trademark.

Copyright ©

Address: Bacancy Systems PVT LTD,
15-16, Times Corporate Park,
Near, Thaltej-Shilaj Road,
Opp. Stone Flats, Thaltej
Ahmedabad, Gujarat,
India, 380059

Website: www.bacancysystems.com

Email: systems@bacancy.com

Phone: +91 90160 28817

All rights reserved, including disposal, exploitation, reproduction, editing, distribution, as well as and utilisation for intellectual property rights.

Liability

The given data is primarily for product description reasons and should not be considered a guaranteed characteristic unless specifically stated in the contract. All rights are retained with regard to the content of this documentation and the availability of the product.

DISCLAIMER

The product, product data and any of its specifications are subject to change without notice. Bacancy Systems PVT LTD, its employees, and all persons acting on its behalf shall not be liable for any errors, inaccuracies, or incompleteness that occur if the methodology contained herein or in any other revelation of the product is not followed. The product specifications alter or amend neither the terms nor conditions of purchase nor the warranty expressed therein.

Bacancy Systems PVT LTD offers no warranty, representation, or guarantee other than as set forth in the terms and conditions of purchase. To the maximum extent permitted by applicable law.

Bacancy Systems PVT LTD, Disclaims

- (i). Any and all liability arising out of the application or use of any product.
- (ii). Any and all liability, including without limitation special, consequential or incidental damages.
- (iii). Any and all implied warranties, including those of merchantability, fitness for a specific purpose, and non-infringement.

The information provided in user guide and/or specifications may differ from actual results in different circumstances, and efficiency may change over time. Statements on a product's appropriateness for a certain application are based on Bacancy Systems PVT LTD's understanding of standard demands that are frequently put on the products of Bacancy Systems PVT LTD. The customer should determine whether a given Bacancy Systems PVT LTD product with the features mentioned in the product specification is appropriate for use in a specific application.

The product shown herein is not designed for use in lifesaving or life-sustaining applications unless otherwise expressly indicated. Customers who utilise or sell Bacancy Systems PVT LTD products that are not explicitly intended for such applications do so solely at their own risk.

This user guide is intended to improve the operator's efficiency throughout the procedure and does not entirely absolve them of responsibility.

Change Record

Rev. No.	Date	Details	Revised By	Approved By
0	06/06/2024	Initial Release	Rajkumar Patel	Samir Bhatt
1	22/04/2025	Legal Entity Conversion: LLP to PVT LTD	Rajkumar Patel	Samir Bhatt

Table of Contents

1. About this Document	7
1.1 Information on the User Guide	7
1.2 Limitations of Liability.....	7
2. Safety	8
2.1 Safety Graphical Pictogram or Symbol	8
2.2 Safety Instruction and Warnings	9
2.3 The Responsibility of Operator	10
2.4 Person in Charge of Operations.....	10
2.5 In an occurrence of Danger or an Accident.....	11
3. Packaging, Transport and Storage	12
3.1 Inspection Packaging and Transport.....	12
3.2 Transport.....	12
3.3 Storage.....	12
4. Intended Use.....	13
4.1 Limitation	13
4.2 Alteration and Restoration of the Product/System.....	13
5. Structure and Function	14
5.1 Overview	14
5.1.1 Feature.....	14
5.1.2 Application.....	14
5.2 Function.....	15
5.2.1 Technical Specification	15
5.2.2 Block Diagram	17
5.2.3 Interface	18
5.2.4 Pin Configuration.....	19
5.2.5 Mechanical Dimension.....	21
6. Appendix.....	22
6.1 Wiring Diagram.....	22
6.2 Abbreviations and Glossary	26

List of Figure

Figure 1 Safety Instruction	8
Figure 2 Bharat DC001 Master Controller	14

List of Table

Table 1 Safety Graphical Pictogram or Symbol	8
Table 2 Digital Input Pins for GUN2	19
Table 3 Digital Output Pins for GUN2.....	19
Table 4 Digital Input Pins for GUN1	19
Table 5 RS-485-1 Communication	19
Table 6 Power Supply	19
Table 7 Additional Input	19
Table 8 CAN0 Communication for Vehicle 1	19
Table 9 Temperature Input Pins for GUN1	19
Table 10 Temperature Input Pins for GUN2.....	20
Table 11 CAN1 Communication for Power Module	20
Table 12 CAN2 Communication for Vehicle 2	20
Table 13 Fan Output	20
Table 14 Digital Output Pins for GUN1.....	20

1. About this Document

1.1 Information on the User Guide

This user guide contains basic information to be considered in the utilisation of the product. A precondition for safe working is the observance of all stated safety instructions and directions. Therefore, this user guide should be read and applied without fail by any person assigned to the installation and operating procedures of the product or system.

This user guide is part of the product, and the case may have to be passed to third parties or the following owners. It must be permanently kept at the usage site and be available for the operating personnel who are responsible for the installation of this product or system.

We are eager to ensure the comprehensiveness, relevance, and up-to-dateness of this user guide. It may become essential to make spontaneous changes to the product and its operation, which may not align with this manual, to maintain our technical advancement. In that case, Bacancy Systems PVT LTD will provide you with a new manual. We exclude liability for disturbances, failures, and resulting damages.

The illustrations in this user guide will provide a better understanding. It can occur that illustrations are not drawn to scale or deviate somewhat from the original.

1.2 Limitations of Liability

All statements and remarks in this user guide have been aggregated with consideration of current standards, laws, and regulations, the state of technology, as well as our extensive knowledge, long-time expertise, and experience. In special models, due to demands for additional order options or the latest technical alterations, the actual scope of delivery can differ from the explanations and elaborations described here.

The manufacturer excludes any liability for damages caused by:

- Inappropriate assembling and installation.
- Non-observance of the user manual.
- Non-intended and improper use.
- Use beyond operation limits.
- Deployment of insufficiently qualified and trained personnel.
- Use of unauthorised spare parts and accessories.

2. Safety

The safety directions, cautions, warnings, and notices are stated here. Moreover, in this user guide's section, the following sections have to be followed to reduce potential health risks and prevent hazardous situations as per the ISO 45001:2018 standard for occupational health and safety.

2.1 Safety Graphical Pictogram or Symbol

These prescribe safety signs for the purposes of accident prevention, fire protection, health hazard information, and emergency evacuation as per the ISO 7010:2019 standard for graphical symbols, safety colours, and registered safety signs.

The safety instructions are structured as follows:

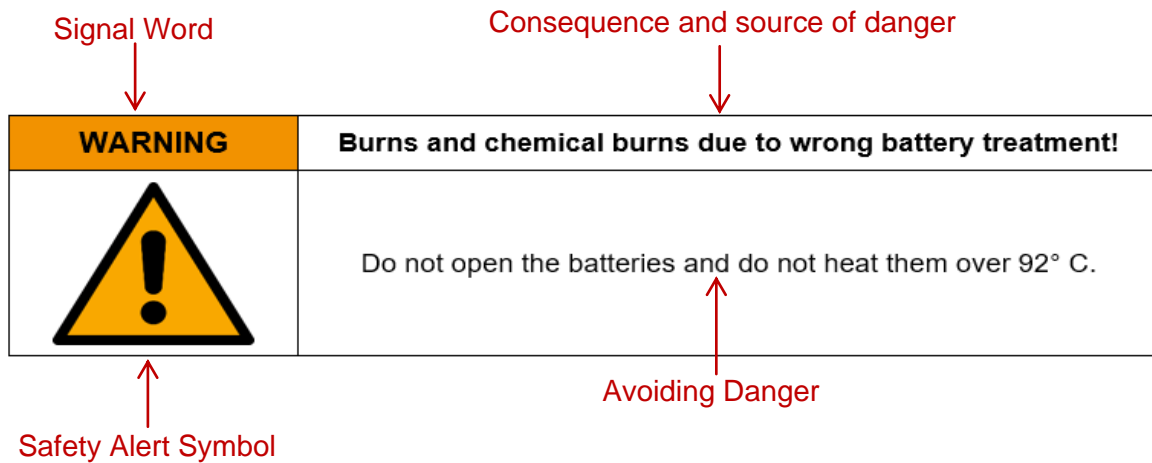











Figure 1 Safety Instruction

Table 1 Safety Graphical Pictogram or Symbol

Pictogram / Symbol	Signal Word	Meaning
	DANGER!	In case of non-compliance with this safety instruction, death or serious injury will occur.
	WARNING!	In case of non-compliance with this safety instruction, death or serious injury can occur.
	CAUTION!	In case of non-compliance with this safety instruction, a minor or moderate injury can occur.
	NOTICE!	In case of non-compliance with this safety instruction, material damage can occur.
	NOTE!	Useful notice or tip on the products or system's easy operation.

2.2 Safety Instruction and Warnings

MANDATORY	Read User Guide
	To get an understanding of the product, the user should pay careful attention to the user guide.
PROHIBITION	Hot Works
	Hot work shall be prohibited in close proximity to fully charged batteries. It will result in a battery explosion.
CAUTION!	Working with Machine Tools Near the Battery
	To prevent the occurrence of sparks, short circuits, or explosions, the user shall take precautions near the operation of a machine tool with a battery.
PROHIBITION	Installation Environment Circumstance
	High concentrations of oxidising or salted gases, wet or dusty surfaces, proximity to sources of extreme heat, open flames, or sparks, or high variation with temperature, proximity to storage of highly flammable materials or gas concentrations, and proximity to areas unprotected from water or high humidity are all prohibited.
MANDATORY	Installation and Maintenance
	Installation and maintenance should be carried out under the supervision or advice of a qualified professional.
PROHIBITION	Assembly and Disassembly
	The assembly or disassembly of an open, repaired, default parameter, or changed production should be prohibited. The warranty could be void and invalid, and the service can be discontinued without notice. The use of a high-pressure washer to clean the product is prohibited.

MANDATORY	Disconnect Power Supply
	<p>The power source or plug should be disconnected in the event of an unanticipated event or when conducting maintenance and repair.</p>

FIRE PROTECTION	Fire Extinguisher
	<p>In the event of a fire, the use of a dry powder fire extinguisher should be advised for fire control, and the use of water should be prohibited.</p>

2.3 The Responsibility of Operator

The product is associated with industrial safety standards. However, the operator who is installing or operating the product is liable for the legal responsibilities for operational safety. In addition to the operational safety instructions in this manual, the safety, accident prevention, and environmental protection regulations valid for the operational area of the product shall be followed.

2.4 Person in Charge of Operations

WARNING!	Risk of injury caused by lack of an adequate qualification!
	<p>Inappropriate handling of the product can lead to severe personal injuries and material damages.</p>

In this manual the following qualification are specified:

Instructed Person	<p>An instructed person is someone who has been instructed by the operator or manufacturer on the given tasks and potential hazards in the event of incorrect behaviour, as well as being semi-skilled and knowledgeable about the necessary safety procedures and safeguards.</p>
Qualified Specialised Professional	<p>Qualified specialised professionals are individuals who are knowledgeable with the assembly, commissioning, and operation of the product and process qualifications related to their work. The specialised individual is able to recognise hazards and prevent potential hazards because of their professional training, knowledge, and experience, as well as their understanding of the appropriate regulations.</p>

2.5 In an occurrence of Danger or an Accident

Preventive Measures:

- Always be prepared for accidents or fires!
- Keep first-aid equipment (ambulance boxes, blankets, etc.) within easy reach.
- Inform personnel with accident alerting, first-aid, and emergency services.
- Keep clear access routes for emergency vehicles.

If the occurrence happens, follow these steps:

- Turn off the product immediately.
- Implement first-aid procedures.
- Get people out of hazardous areas.
- Inform the appropriate person at the usage spot.
- Contact a doctor and/or the fire department.

3. Packaging, Transport and Storage

3.1 Inspection Packaging and Transport

The products have been properly secured to ensure sufficient safeguarding during shipment. Please scrutinise the delivered products for overall quality and transportation problems as soon as possible.

In the instance of external shipment damage, proceed as follows:

- Do not accept delivery or accept it only on reserve.
- Issue a complaint.
- Do not use items that are obviously defective.

3.2 Transport

Always ensure that your equipment is transported in safe and appropriate containers while transporting it to the usage location or in the field.

Never transfer everything in an unplanned way in the vehicle. Hits and thrusts might seriously impair the product's functionality.

Always use the original packaging, transport containers, transport boxes, or equivalent packaging, whether transporting by train, aircraft, or ship. The container shields the goods from impacts and vibrations.

3.3 Storage

Strictly store the product in well-ventilated, dry spaces. During storage, keep it dry and leverage the original packaging if possible.

Avoid extreme heat fluctuations during storage. The initiation of water condensation can impair the product's operation.

When storing, keep in mind the temperature restrictions of the product. Please refer to the product's technical data for valid storage temperatures.

4. Intended Use

The purpose of this user guide is to give you basic information about the Bharat DC001 Master Controller. This user guide is mainly focused on the technical aspects of Bharat DC001 Master Controller, which are covered in this user guide in graphical and tabular formats in various sections, as listed below:

Sections 1–3 featured information concerning the document and product's liability, safety, packing, transportation, and storage constraints. These first three parts will help you know how to follow pre-conception practises that must be followed before, during, and after utilising the product.

Section five contains technical information about the Bharat DC001 Master Controller, such as its functions, features, and applications, as well as their technical specifications, and a block diagram for the described internal architecture of the controller with communication protocol, interface, and its functions describe how to configure and integrate the Bharat DC001 Master Controller with additional components, and mechanical dimension useful for installation understanding.

Finally, the appendix section included a wiring diagram and an abbreviation and glossary, as well as the company's help desk and contact information.

WARNING!	Risk caused by inappropriate use!
	<p>Any unconventional use and/or different operation of the product can lead to hazardous situations.</p> <ul style="list-style-type: none"> • Only use the product in a conventional manner.

4.1 Limitation

The product is intended for use in an operational environment. It should not be used in hostile or explosive conditions.

The operator should consult local safety authorities and safety representatives before performing tasks in hazardous areas or in similar circumstances.

4.2 Alteration and Restoration of the Product/System

To prevent risks and make sure optimal performance, no alterations, attachments, or restoration of the product are permitted without explicit authorisation of Bacancy Systems PVT LTD.

5. Structure and Function

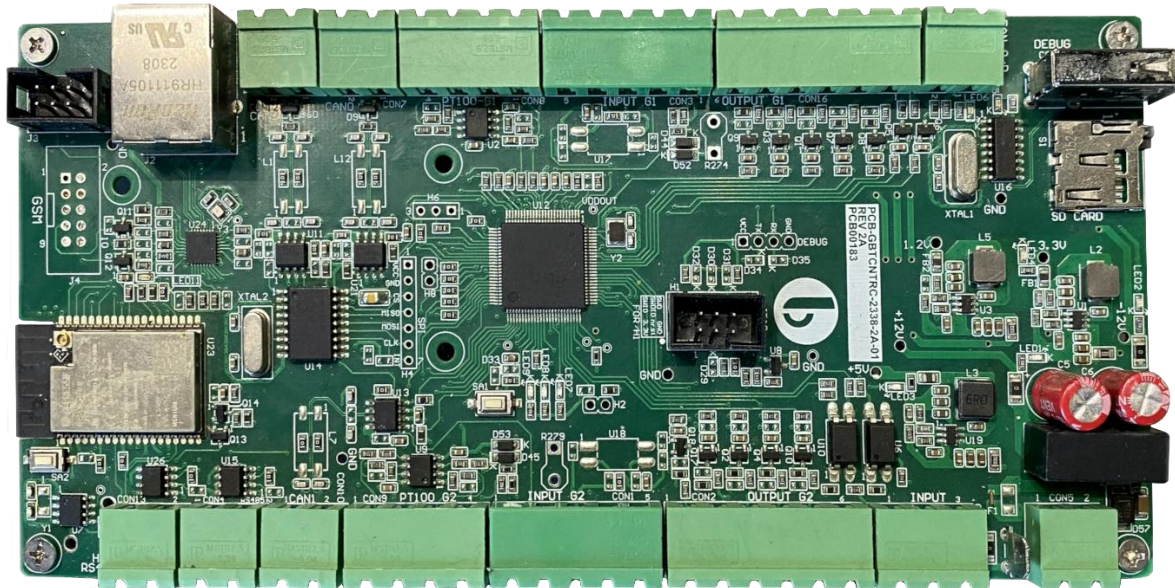

Figure 2 Bharat DC001 Master Controller

Bacancy's Bharat DC001 Master Controller offers the leading edge of electric vehicle (EV) charging technology. It is designed to comply with the BEVC-DC001 and GB/T 20234.3-2015 standard, which includes both efficiency and safety requirements, making it a suitable option for powering four-wheeler EVs. It prioritises efficiency and safety while supporting a wide range of charging requirements, including voltages of up to 200 V DC and currents of up to 100 A.

5.1 Overview

5.1.1 Feature

List of Feature

- Up to 20 kW Output Capacity
- Configurable for Single Gun / Dual Gun (GB/T 20234)
- Supports Fully Customisable HMI Displays (Modbus RTU)
- RFID Authentication & LED Indicators
- Compatible with E-Control GUN Locking System

5.1.2 Application

List of Applications

- Four-Wheeler Charger Controller

5.2 Function

5.2.1 Technical Specification

Product Properties	
Product Type	Bharat DC001 Master Controller
Product Family	DC Charger Controller
Application	Four-Wheel Charger Controller
Input Power	
Supply Voltage	415 V AC \pm 10%
AC Input Connection	3P+PE+N
Frequency	50 Hz and 60 Hz
Controller Voltage	12 V DC @ 2A
Output Power	
Total Output	Up to 20 kW
Output Voltage	200 V DC @ 100A
Support Gun	Single Gun / Dual Gun
Support Connector	GB/T 20234
Communication	
Protocol	OCPP 1.6j, Upgradeable to OCPP 2.0.1 (Ethernet, Wi-Fi & GSM)
Network Connection	Ethernet 10/100 LTE (4G fallback to 2G), Wi-Fi 802.11 b/g/n (802.11n up to 150 Mbps)
Interface	
Power Module Interface	CAN 2.0
Charger and Vehicle communication	CAN 2.0
Power Measurement	RS-485 (Modbus RTU Master)
HMI Interface	RS-485 (Modbus RTU Slave)
Add on	RS-485 (AC Meter, HMI, LED & RFID)
Digital Input	4 Nos. (12V Logic)
Digital Output	6 Nos. (Open Collector) per Connector
Temperature Input	4 Nos.
Ambient Condition	
Operating Temperature	-10°C to 70°C
Storage / Transport Temperature	-10°C to 70°C
Permissible Humidity	5% to 95%
Mechanical Properties	
Dimension	210 x 120 x 59 mm
Weight	100 g
Add-on Board	
RFID Module (MF RC522, 13.56 MHz), LED Module, HMI Display and Solenoid Lock Module	
Storage Memory	
Micro-SD Card Supported; Expandable Storage Up to 32 GB	

Firmware Upgrade

Firmware Over-The-Air (FOTA)

Standard Support

BEVC-DC001, GB/T 20234.3-2015

5.2.2 Block Diagram

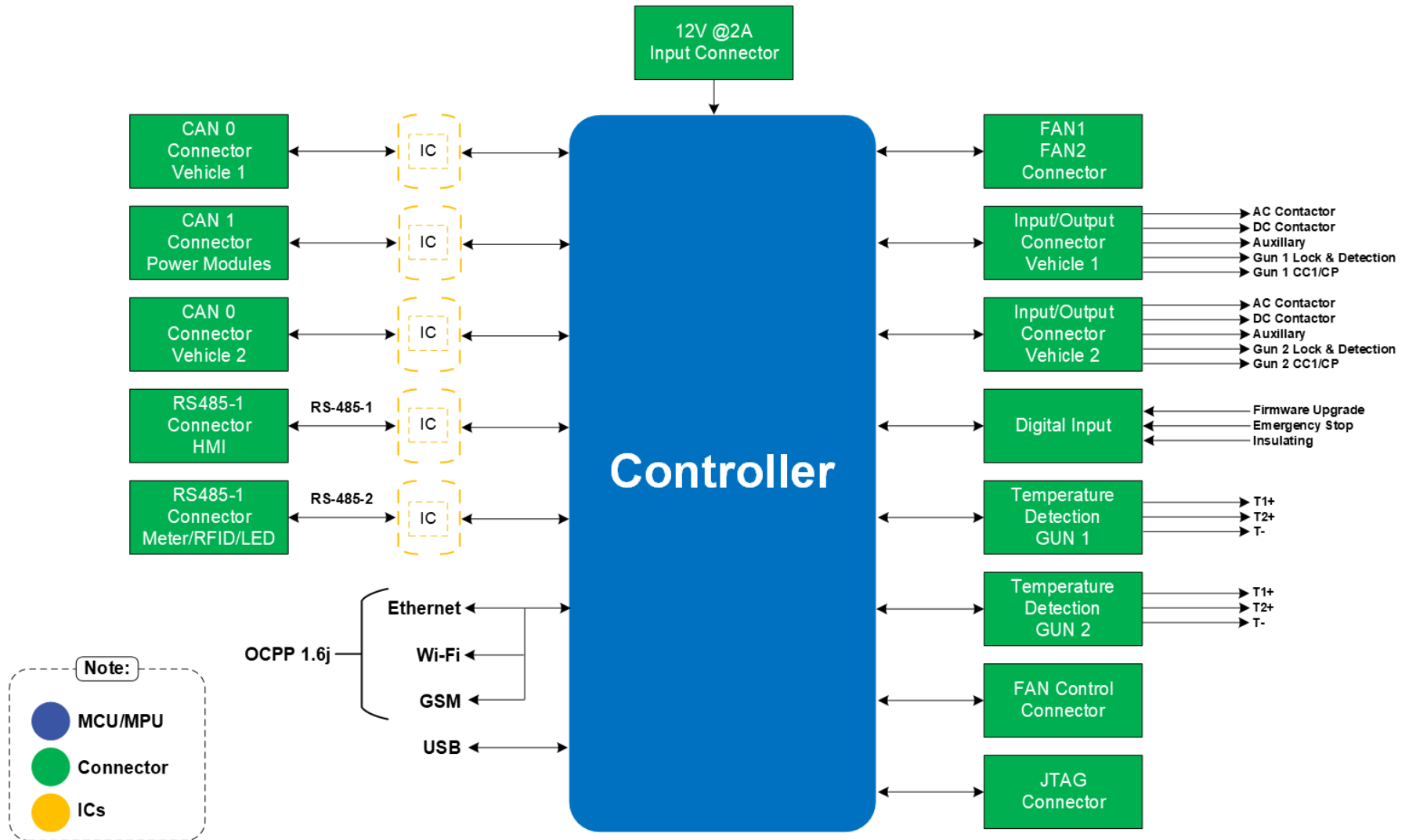

5.2.3 Interface

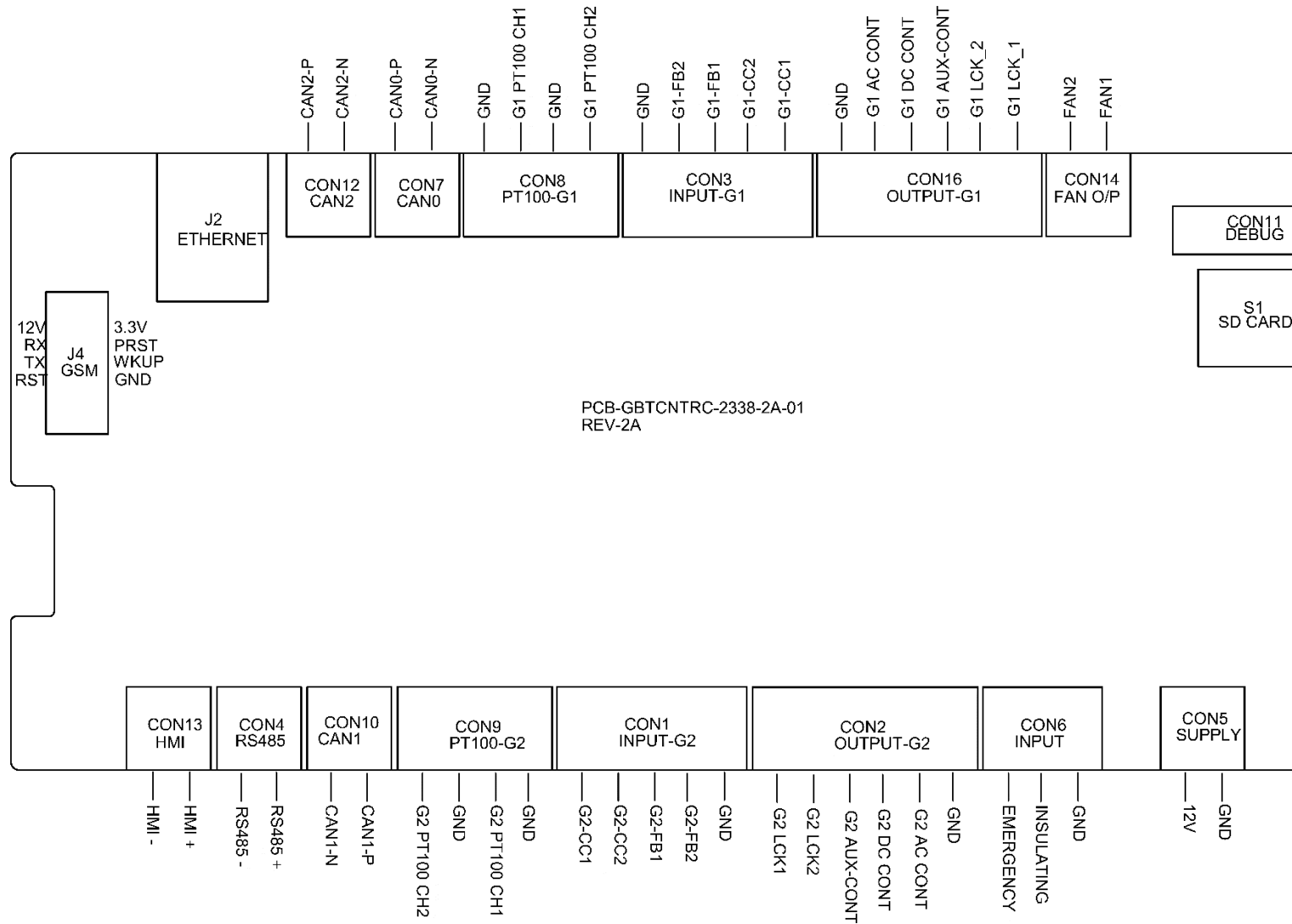

5.2.4 Pin Configuration

Table 2 Digital Input Pins for GUN2

No.	Connector	Pin	Signal Name	Description
1	CON 1	1	G2-CC1	Control Pilot for Gun 2
2		2	G2-CC2	-
3		3	G2-FB1	Feedback Signal 1 for Gun 2 Lock / Unlock
4		4	G2-FB2	Feedback Signal 2 for Gun 2 Lock / Unlock
5		5	GND	Ground

Table 3 Digital Output Pins for GUN2

No.	Connector	Pin	Signal Name	Description
1	CON 2	1	G2-LCK1	Gun 2 Lock 1
2		2	G2-LCK2	Gun 2 Lock 2
3		3	G2-AUX-CONT	Gun 2 Auxiliary Contactor
4		4	G2-DC-CONT	Gun 2 DC Contactor
5		5	G2-AC-CONT	Gun 2 AC Contactor
6		6	GND	Ground

Table 4 Digital Input Pins for GUN1

No.	Connector	Pin	Signal Name	Description
1	CON 3	1	G1-CC1	Control Pilot for Gun 1
2		2	G1-CC2	-
3		3	G1-FB1	Feedback Signal 1 for Gun 1 Lock / Unlock
4		4	G1-FB2	Feedback Signal 2 for Gun 1 Lock / Unlock
5		5	GND	Ground

Table 5 RS-485-1 Communication

No.	Connector	Pin	Signal Name	Description
1	CON 4	1	RS-485 (A)+	RS-485-1 (A) Transmitter
2		2	RS-485 (B)-	RS-485-1 (B) Receiver

Table 6 Power Supply

No.	Connector	Pin	Signal Name	Description
1	CON 5	1	12V	Controller Power Supply
2		2	GND	Ground

Table 7 Additional Input

No.	Connector	Pin	Signal Name	Description
1	CON 6	1	EMERGENCY	Emergency Button
2		2	INSULATING	Insulating Monitoring
3		3	GND	Ground

Table 8 CAN0 Communication for Vehicle 1

No.	Connector	Pin	Signal Name	Description
1	CON 7	1	CAN0-N	CAN0-Low
2		2	CAN0-P	CAN0-High

Table 9 Temperature Input Pins for GUN1

No.	Connector	Pin	Signal Name	Description
1	CON 8	1	G1-PT100 CH2	G1-PT100 Channel 2
2		2	GND	Ground
3		3	G1-PT100 CH1	G1-PT100 Channel 1
4		4	GND	Ground

Table 10 Temperature Input Pins for GUN2

No.	Connector	Pin	Signal Name	Description
1	CON 9	1	G2-PT100 CH2	G2-PT100 Channel 2
2		2	GND	Ground
3		3	G2-PT100 CH1	G2-PT100 Channel 1
4		4	GND	Ground

Table 11 CAN1 Communication for Power Module

No.	Connector	Pin	Signal Name	Description
1	CON 10	1	CAN2-N	CAN2-Low
2		2	CAN2-P	CAN2-High

Table 12 CAN2 Communication for Vehicle 2

No.	Connector	Pin	Signal Name	Description
1	CON 12	1	CAN2-N	CAN2-Low
2		2	CAN2-P	CAN2-High

Table 13 Fan Output

No.	Connector	Pin	Signal Name	Description
1	CON 14	1	FAN1	FAN +12 V Relay
2		2	FAN2	3.3 V Output

Table 14 Digital Output Pins for GUN1

No.	Connector	Pin	Signal Name	Description
1	CON 16	1	G1-LCK1	Gun 1 Lock 1
2		2	G1-LCK2	Gun 1 Lock 2
3		3	G1-AUX-CONT	Gun 1 Auxiliary Contactor
4		4	G1-DC-CONT	Gun 1 DC Contactor
5		5	G1-AC-CONT	Gun 1 AC Contactor
6		6	GND	Ground

5.2.5 Mechanical Dimension

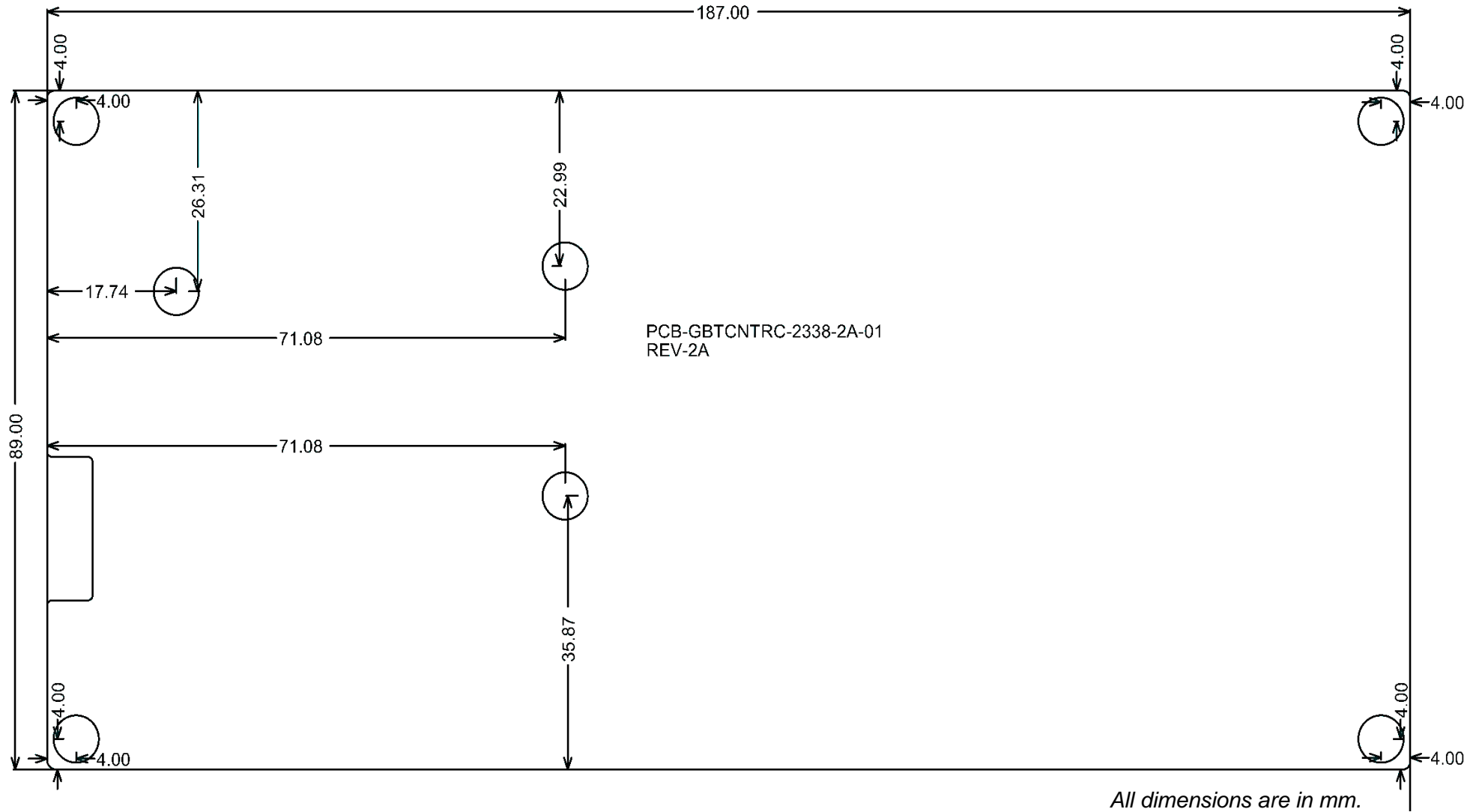

6. Appendix

6.1 Wiring Diagram

Please refer the next page.

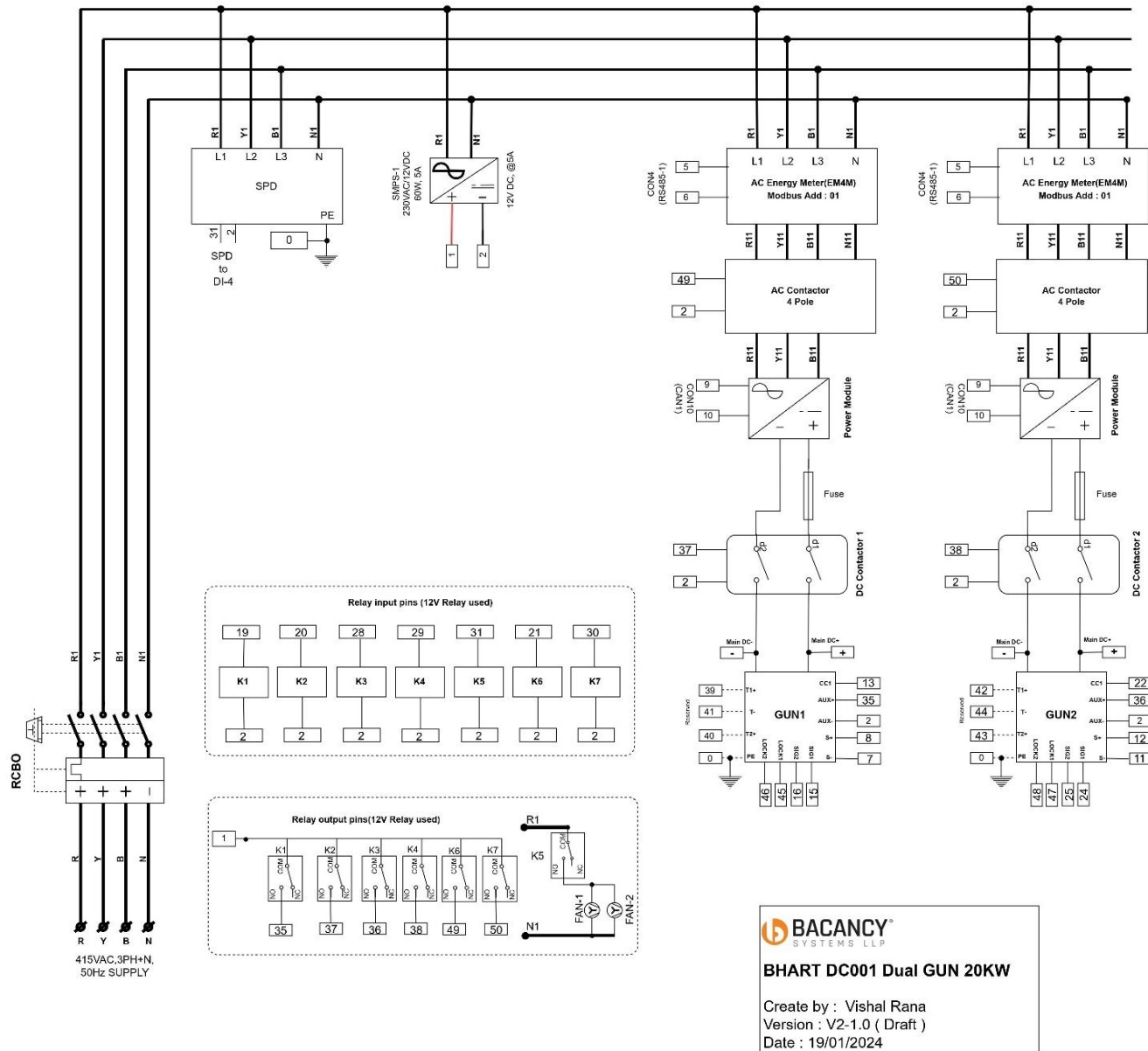

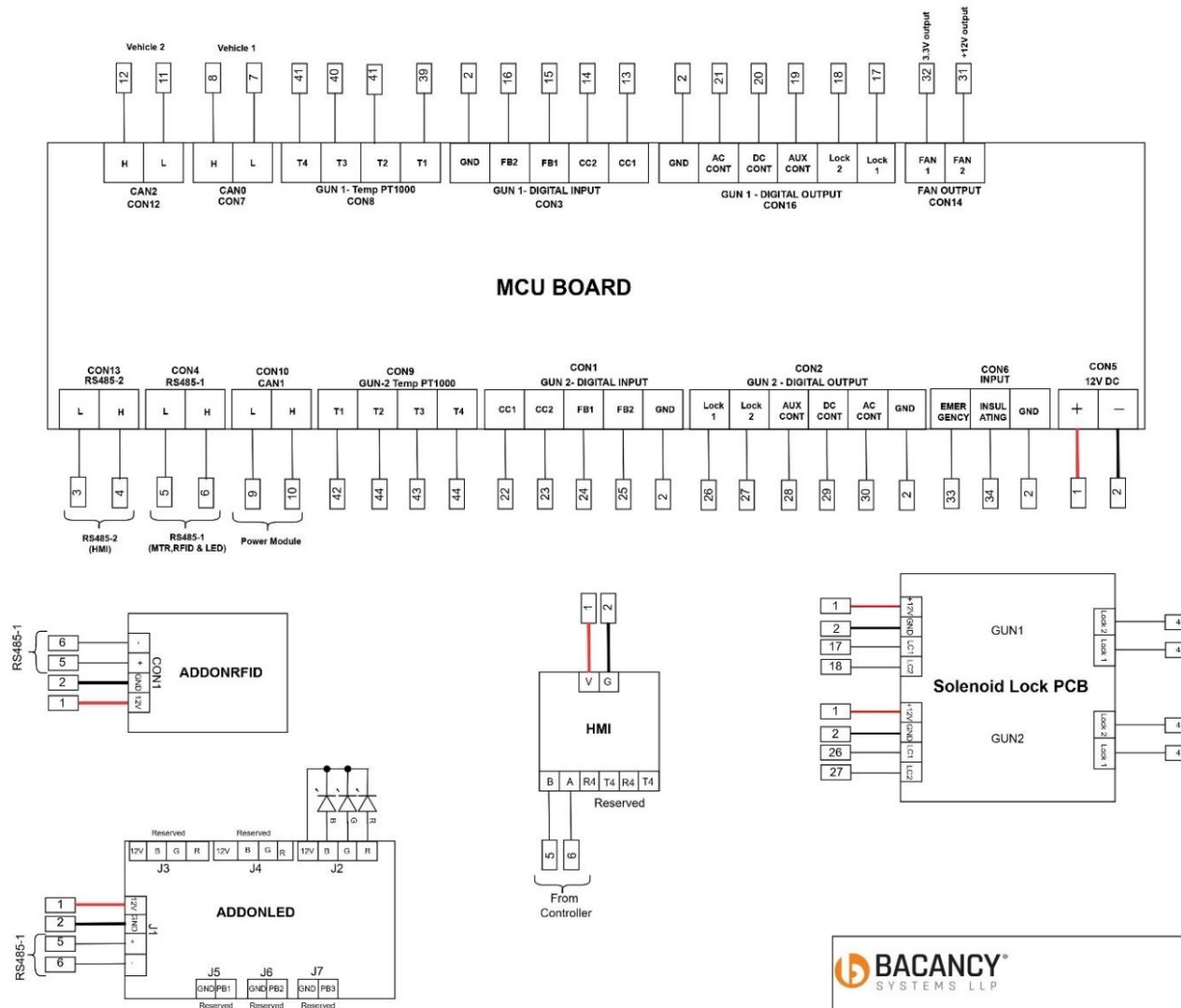

BACANCY[®]
SYSTEMS LLP

BHART DC001 DUAL GUN 20KW

Create by : Vishal Rana
Version : 2V-1.0 (Draft)
Date : 19/01/2024

Pins Identification

Pin No	USE	Details	Connector
0	PE (Earth)		
1	12V DC	12V Supply	CON 5
2	GND		
3	RS485 L	RS485-2	CON 13
4	RS485 H		
5	RS485 L	RS485-1	CON 4
6	RS485 H		
7	CAN L	CAN 0	CON 0
8	CAN H		
9	CAN L	CAN 1	CON 10
10	CAN H		
11	CAN L	CAN 2	CON 2
12	CAN H		
13	CC1	Digital Input pins for GUN 1	CON 3
14	CC2		
15	FB 1		
16	FB 2		
17	LOCK 1	Digital Outout pins for GUN 1	CON 16
18	LOCK 2		
19	Auxiliary Contactor		
20	DC Contactor		
21	AC Contactor		
22	CC1	Digital Input pins for GUN 2	CON 1
23	CC2		
24	FB 1		
25	FB 2		
26	LOCK 1	Digital Outout pins for GUN 2	CON 2
27	LOCK 2		
28	Auxiliary Contactor		
29	DC Contactor		
30	AC Contactor		
31	FAN 2	3.3V output	CON 14
32	FAN 1	FAN + 12V Relay	
33	EMERGENCY STOP	INPUT	CON 5
34	INSULATING		
35	Auxiliary relay to GUN 1	Relay out put to GUN	
36	Auxiliary relay to GUN 2		
37	Relay output to DC CONTACTOR	Relay to DC Contactor supply	
38	Relay output to DC CONTACTOR		
39	TEMP CH1	GUN 1	CON 8
40	TEMP CH2		
41	T-		
42	TEMP CH1	GUN 2	CON 9
43	TEMP CH2		
44	T-		
45	Solenoid lock 1	GUN 1	Solenoid lock PCB to GUN1 & GUN2
46	Solenoid lock 2		
47	Solenoid lock 1	GUN 2	
48	Solenoid lock 2		
49	AC Contactor relay to GUN 1	Relay out to AC Contactor	
50	AC Contactor relay to GUN 2		

Relay List		
Relay No	Details	USE
K1	Auxiliary Supply GUN1	
K2	DC Contactor GUN1	GUN1
K3	Auxiliary Supply GUN2	
K4	DC Contactor GUN2	GUN2
K5	FAN	
K6	AC Contactor GUN1	GUN1
K7	AC Contactor GUN2	GUN2

Note:-

1. This wiring diagram is for single and dual guns. For single gun use, disregard the gun 2 connection.
2. Use separate 12V SMPS(one for MCU board,RFID addon, LED addon & 2nd for Relay board,Contactor and Solenoid Board)
3. If you are not using an AC contactor, then you can disregard relay 6 and Relay 7
4. In the controller board connector 14, pin 1 produces 12V, and pin 2 generates 3.3V for future updates.



BHART DC001DUAL GUN 20KW

Create by : Vishal Rana
Version : 2V-1.0 (Draft)
Date : 19/01/2024

6.2 Abbreviations and Glossary

3P+N+PE	<i>A 3-phase 4-wire + PE system is an electrical power distribution system that consists of three conductors carrying alternating current (AC) power, a neutral conductor, and a protective earth conductor.</i>
AC	<i>Alternating current, is a type of electrical current in which the current repeatedly changes direction.</i>
BEVC-DC001	<i>BEVC-DC001 is a charging standard for electric vehicles (EVs) in India. The charger uses the GB/T 20234 connector for conductive connection to the vehicle. Its purpose is to standardize charging protocols and promote.</i>
CAN 2.0	<i>CAN 2.0 (Controller Area Network 2.0) is a vehicle bus standard designed to facilitate efficient communication primarily between electronic control units (ECUs).</i>
CON	<i>Connector</i>
CP	<i>Control Pilot is a communication line used to negotiate charging levels between the car and the EVSE, and it can be manipulated by the vehicle to initiate charging and carry other information.</i>
DC	<i>Direct current (DC) is one-directional flow of electric charge.</i>
EV	<i>An EV is defined as a vehicle that can be powered by an electric motor that draws electricity from a battery and is capable of being charged from an external source.</i>
FOTA	<i>Firmware over-the-air update is a updated that is downloaded by the device over the internet.</i>
GB/T 20234.3-2015	<i>The GB/T charging standard is a set of GB/T standards, primarily in the GB/T 20234 family, for electric vehicle AC and DC fast charging used in China. The standards were revised and updated most recently in 2015 by the Standardization Administration of China.</i>
GND	<i>GND stands for Ground. A common or shared return route of electrical current to the power source that enables the completion of the circuit refers to the ground in both electrical and electronic circuits.</i>
HMI	<i>HMI stands for Human Machine Interface. Generally, it refers to a screen or dashboard that communicates information, data, and metrics using graphics or visual representations of numbers. The screen is controlled by an operator who monitors and controls equipment and processes.</i>
Hz	<i>hertz, the SI unit of frequency, is equal to one cycle per second.</i>

<i>kW</i>	<i>KW is a kilowatt. KW is used to represent the actual power that carries out the work.</i>
<i>LED</i>	<i>A light-emitting diode (LED) is a semiconductor device that emits light when current flows through it.</i>
<i>Micro-SD Card</i>	<i>Micro SD card is a compact form of Secure Digital (SD) card used for storing data in various electronic devices.</i>
<i>OCPP 1.6</i>	<i>The OCPP 1.6 (Open Charge Point Protocol) enables the integration of equipment from different manufacturers.</i>
<i>RFID</i>	<i>Radio-frequency identification (RFID) uses electromagnetic fields to automatically identify, and track tags attached to objects.</i>
<i>RS-485</i>	<i>RS-485 is an industrial specification that defines the electrical interface and physical layer for point-to-point communication of electrical devices. The RS-485 standard allows for long cabling distances in electrically noisy environments and can support multiple devices on the same bus.</i>
<i>VAC</i>	<i>VAC (Volts Alternating Current) is a measure of the strength of the alternating electric field that drives the flow of electrons in AC electrical systems.</i>
<i>VDC</i>	<i>VDC refers to volts of direct current, and it can come from either a battery or a power supply that converts AC (alternating current) into DC.</i>
<i>Wi-Fi</i>	<i>Wi-Fi is a family of wireless network protocols based on the IEEE 802.11 family of standards, which are commonly used for local area networking of devices and internet access, allowing nearby digital devices to exchange data by radio waves.</i>

 **Bacancy Systems PVT LTD,**
15-16, Times Corporate Park,
Near, Thaltej-Shilaj Road,
Opp. Stone Flats, Thaltej
Ahmedabad, Gujarat,
India, 380059

 www.bacancysystems.com

 systems@bacancy.com

 +91 90160 28817

 **Helpdesk:** <https://bacancy.freshdesk.com/a/dashboard/default>