

User Guide

Rope Charger Controller

7.4 kW / 3.3 kW

Please completely read this document and the contained safety instructions and note all given information before usage.

Please maintain the confidentiality of this user guide. It is intended solely for usage by people professionally associated with the product. If you are not the intended recipient, you may not disclose or use the information in this documentation. The information does not constitute an offer or solicitation to buy or sale of any security.

This user guide's text and illustrations have been meticulously crafted. However, we may not be held accountable for any discrepancies or failure consequences.

Some company and label names are protected by a label, a patent, or a trademark.

Copyright ©

Address: Bacancy Systems PVT LTD,
15-16, Times Corporate Park,
Near Thaltej-Shilaj Road,
Opp. Copper Stone Flats,
Thaltej, Ahmedabad,
Gujarat, India, 380059

Website: www.bacancysystems.com

Email: systems@bacancysystems.com

Phone: +91 90160 28817

All rights reserved, including disposal, exploitation, reproduction, editing, distribution, as well as and utilisation for intellectual property rights.

Liability

The given data is primarily for product description reasons and should not be considered a guaranteed characteristic unless specifically stated in the contract. All rights are retained with regard to the content of this documentation and the availability of the product.

DISCLAIMER

The product, product data and any of its specifications are subject to change without notice. Bacancy Systems PVT LTD, its employees, and all persons acting on its behalf shall not be liable for any errors, inaccuracies, or incompleteness that occur if the methodology contained herein or in any other revelation of the product is not followed. The product specifications alter or amend neither the terms nor conditions of purchase nor the warranty expressed therein.

Bacancy Systems PVT LTD offers no warranty, representation, or guarantee other than as set forth in the terms and conditions of purchase. To the maximum extent permitted by applicable law.

Bacancy Systems PVT LTD, Disclaims

- (i). Any and all liability arising out of the application or use of any product.
- (ii). Any and all liability, including without limitation special, consequential or incidental damages
- (iii). Any and all implied warranties, including those of merchantability, fitness for a specific purpose, and non-infringement.

The information provided in user guide and/or specifications may differ from actual results in different circumstances, and efficiency may change over time. Statements on a product's appropriateness for a certain application are based on Bacancy Systems PVT LTD's understanding of standard demands that are frequently put on the products of Bacancy Systems PVT LTD. The customer should determine whether a given Bacancy Systems PVT LTD product with the features mentioned in the product specification is appropriate for use in a specific application.

The product shown herein is not designed for use in lifesaving or life-sustaining applications unless otherwise expressly indicated. Customers who utilise or sell Bacancy Systems PVT LTD products that are not explicitly intended for such applications do so solely at their own risk.

This user guide is intended to improve the operator's efficiency throughout the procedure and does not entirely absolve them of responsibility.

Change Record

Rev. No.	Date	Details	Revised By	Approved By
0	30/07/2024	Initial Release	Rajkumar Patel	Samir Bhatt
1	24/09/2024	Update in <ul style="list-style-type: none"> Section 5.2.1 Technical Specification. Figures 4 and 5 LED Module. 	Rajkumar Patel	Samir Bhatt
2	22/04/2025	Legal Entity Conversion: LLP to PVT LTD	Rajkumar Patel	Samir Bhatt
3	03/09/2025	Update in <ul style="list-style-type: none"> Section 5.2.1 Technical Specification. Section 5.2.4 Pin Configuration 	Rajkumar Patel	Chirag Rana
4	10/03/2026	Update in <ul style="list-style-type: none"> Section 5.2.6: Switch (SW) 2: The time delay is set to a maximum of 12 hours. Section 6.1: LED Status 	Nikunj Baraiya	Samir Bhatt
5	02/04/2026	Update in <ul style="list-style-type: none"> Section 5.2.1: Technical Specification of Maximum Output Current and Power 	Nikunj Baraiya	Samir Bhatt
6	09/04/2026	Addition <ul style="list-style-type: none"> Section 7: Fault Management 	Rajkumar Patel	Samir Bhatt
7	23/04/2026	Update in <ul style="list-style-type: none"> Section 5.2.6: LED Module Section 6.2: Earth Fault Status 	Nikunj Baraiya	Samir Bhatt

Table of Contents

1. About this Document.....	8
1.1 Information on the User Guide.....	8
1.2 Limitations of Liability.....	8
2. Safety.....	9
2.1 Safety Graphical Pictogram or Symbol	9
2.2 Safety Instruction and Warnings	10
2.3 The Responsibility of Operator	11
2.4 Person in Charge of Operations	11
2.5 In an occurrence of Danger or an Accident.....	12
3. Packaging, Transport and Storage.....	13
3.1 Inspection Packaging and Transport.....	13
3.2 Transport.....	13
3.3 Storage.....	13
4. Intended Use	14
4.1 Limitation	14
4.2 Alteration and Restoration of the Product/System.....	14
5. Structure and Function.....	15
5.1 Overview	15
5.1.1 Feature	15
5.1.2 Application	15
5.2 Function.....	16
5.2.1 Technical Specification	16
5.2.2 Block Diagram	17
5.2.3 The Connector Interface	18
5.2.4 Pin Configuration	19
5.2.5 Mechanical Diagram	21
5.2.6 LED Module.....	22
6. Interpretation of Visual Indication	23
6.1 LED Status	23
6.2 Fault Status	23
7. Fault Management	26
7.1 Recovery Mode	27
8. Appendix	28
8.1 Abbreviations and Glossary.....	28

List of Figures

Figure 1 Safety Instruction	9
Figure 2 Rope Charger Controller	15
Figure 3 Switches 1 and 2 are for Setting the Current and Time Delay for LED Module.....	22
Figure 5 Switches 1 and 2 are for Setting the Current and Time Delay.	22
Figure 5 RGB LED Strip Connector.....	22

List of Tables

Table 1 Safety Graphical Pictogram or Symbol	9
Table 2 Input Power Supply	19
Table 3 Output Power Supply	19
Table 4 Communication Channel	19
Table 5 PT1000 Temperature Sensor	19
Table 6 12 VDC Power Output Supply	19
Table 7 RGB LED Module Connection	19
Table 8 NTC Temperature Sensor Connection	19
Table 9 TFT 1.8" Display Module Connection	20
Table 10 RCD Connection	20
Table 11 RGB LED Connection with Mother Card	20
Table 12 RGB LED Strip Module Connection with Mother Card	20
Table 13 RGB LED Strip Connection	20
Table 14 LED Status and Its Meaning	23
Table 15 Fault Type and Recovery.	26

1. About this Document

1.1 Information on the User Guide

This user guide contains basic information to be considered in the utilisation of the product. A precondition for safe working is the observance of all stated safety instructions and directions. Therefore, this user guide should be read and applied without fail by any person assigned to the installation and operating procedures of the product or system.

This user guide is part of the product, and the case may have to be passed to third parties or the following owners. It must be permanently kept at the usage site and be available for the operating personnel who are responsible for the installation of this product or system.

We are eager to ensure the comprehensiveness, relevance, and up-to-dateness of this user guide. It may become essential to make spontaneous changes to the product and its operation, which may not align with this manual, to maintain our technical advancement. In that case, Bacancy Systems PVT LTD will provide you with a new manual. We exclude liability for disturbances, failures, and resulting damages.

The illustrations in this user guide will provide a better understanding. It can occur that illustrations are not drawn to scale or deviate somewhat from the original.

1.2 Limitations of Liability

All statements and remarks in this user guide have been aggregated with consideration of current standards, laws, and regulations, the state of technology, as well as our extensive knowledge, long-time expertise, and experience. In special models, due to demands for additional order options or the latest technical alterations, the actual scope of delivery can differ from the explanations and elaborations described here.

The manufacturer excludes any liability for damages caused by:

- Inappropriate assembling and installation.
- Non-observance of the user manual.
- Non-intended and improper use.
- Use beyond operation limits.
- Deployment of insufficiently qualified and trained personnel.
- Use of unauthorised spare parts and accessories.

2. Safety

The safety directions, cautions, warnings, and notices are stated here. Moreover, in this user guide’s section, the following sections have to be followed to reduce potential health risks and prevent hazardous situations as per the ISO 45001:2018 standard for occupational health and safety.

2.1 Safety Graphical Pictogram or Symbol

These prescribe safety signs for the purposes of accident prevention, fire protection, health hazard information, and emergency evacuation as per the ISO 7010:2019 standard for graphical symbols, safety colours, and registered safety signs.

The safety instructions are structured as follows:

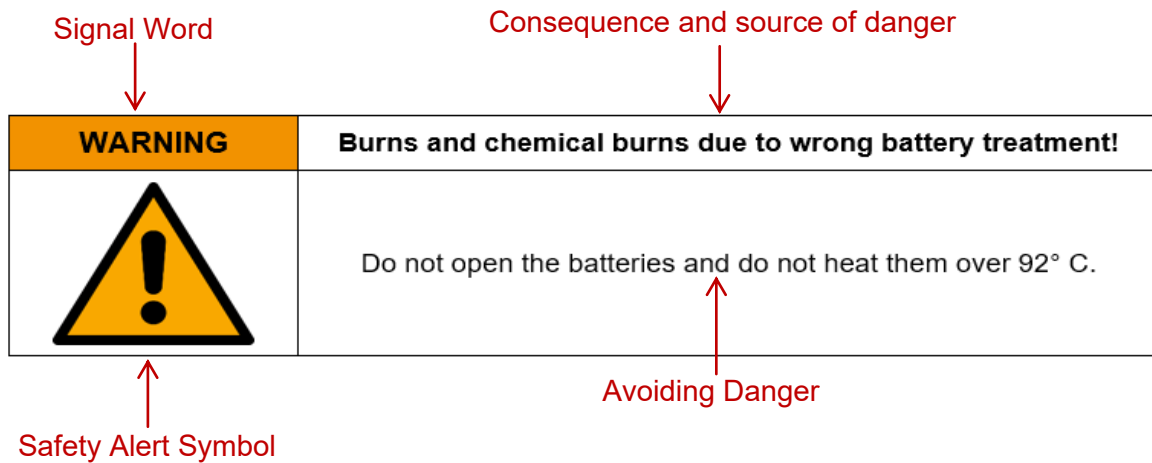











Figure 1 Safety Instruction

Table 1 Safety Graphical Pictogram or Symbol

Pictogram / Symbol	Signal Word	Meaning
	DANGER!	In case of non-compliance with this safety instruction, death or serious injury will occur.
	WARNING!	In case of non-compliance with this safety instruction, death or serious injury can occur.
	CAUTION!	In case of non-compliance with this safety instruction, a minor or moderate injury can occur.
	NOTICE!	In case of non-compliance with this safety instruction, material damage can occur.
	NOTE!	Useful notice or tip on the products or system’s easy operation.

2.2 Safety Instruction and Warnings

MANDATORY	Read User Guide
	To get an understanding of the product, the user should pay careful attention to the user guide.
PROHIBITION	Hot Works
	Hot work shall be prohibited in close proximity to fully charged batteries. It will result in a battery explosion.
CAUTION!	Working with Machine Tools Near the Battery
	To prevent the occurrence of sparks, short circuits, or explosions, the user shall take precautions near the operation of a machine tool with a battery.
PROHIBITION	Installation Environment Circumstance
	High concentrations of oxidising or salted gases, wet or dusty surfaces, proximity to sources of extreme heat, open flames, or sparks, or high variation with temperature, proximity to storage of highly flammable materials or gas concentrations, and proximity to areas unprotected from water or high humidity are all prohibited.
MANDATORY	Installation and Maintenance
	Installation and maintenance should be carried out under the supervision or advice of a qualified professional.
PROHIBITION	Assembly and Disassembly
	The assembly or disassembly of an open, repaired, default parameter, or changed production should be prohibited. The warranty could be void and invalid, and the service can be discontinued without notice. The use of a high-pressure washer to clean the product is prohibited.

MANDATORY	Disconnect Power Supply
	<p>The power source or plug should be disconnected in the event of an unanticipated event or when conducting maintenance and repair.</p>

FIRE PROTECTION	Fire Extinguisher
	<p>In the event of a fire, the use of a dry powder fire extinguisher should be advised for fire control, and the use of water should be prohibited.</p>

2.3 The Responsibility of Operator

The product is associated with industrial safety standards. However, the operator who is installing or operating the product is liable for the legal responsibilities for operational safety. In addition to the operational safety instructions in this manual, the safety, accident prevention, and environmental protection regulations valid for the operational area of the product shall be followed.

2.4 Person in Charge of Operations

WARNING!	Risk of injury caused by lack of an adequate qualification!
	<p>Inappropriate handling of the product can lead to severe personal injuries and material damages.</p>

In this manual the following qualification are specified:

Instructed Person	<p>An instructed person is someone who has been instructed by the operator or manufacturer on the given tasks and potential hazards in the event of incorrect behaviour, as well as being semi-skilled and knowledgeable about the necessary safety procedures and safeguards.</p>
Qualified Specialised Professional	<p>Qualified specialised professionals are individuals who are knowledgeable with the assembly, commissioning, and operation of the product and process qualifications related to their work. The specialised individual is able to recognise hazards and prevent potential hazards because of their professional training, knowledge, and experience, as well as their understanding of the appropriate regulations.</p>

2.5 In an occurrence of Danger or an Accident

Preventive Measures:

- Always be prepared for accidents or fires!
- Keep first-aid equipment (ambulance boxes, blankets, etc.) within easy reach.
- Inform personnel with accident alerting, first-aid, and emergency services.
- Keep clear access routes for emergency vehicles.

If the occurrence happens, follow these steps:

- Turn off the product immediately.
- Implement first-aid procedures.
- Get people out of hazardous areas.
- Inform the appropriate person at the usage spot.
- Contact a doctor and/or the fire department.

3. Packaging, Transport and Storage

3.1 Inspection, Packaging, and Transport

The products have been properly secured to ensure sufficient safeguarding during shipment. Please scrutinise the delivered products for overall quality and transportation problems as soon as possible.

In the instance of external shipment damage, proceed as follows:

- Do not accept delivery or accept it only on reserve.
- Issue a complaint.
- Do not use items that are obviously defective.

3.2 Transport

Always ensure that your equipment is transported in safe and appropriate containers while transporting it to the usage location or in the field.

Never transfer everything in an unplanned way in the vehicle. Hits and thrusts might seriously impair the product's functionality.

Always use the original packaging, transport containers, transport boxes, or equivalent packaging, whether transporting by train, aircraft, or ship. The container shields the goods from impacts and vibrations.

3.3 Storage

Strictly store the product in well-ventilated, dry spaces. During storage, keep it dry and leverage the original packaging if possible.

Avoid extreme heat fluctuations during storage. The initiation of water condensation can impair the product's operation.

When storing, keep in mind the temperature restrictions of the product. Please refer to the product's technical data for valid storage temperatures.

4. Intended Use

The purpose of this user guide is to give you basic information about the rope charger controller. This user guide is mainly focused on the technical aspects of the controller, which are covered in this user guide in graphical and tabular formats in various sections, as listed below:

Sections 1-3 featured information concerning the document and product's liability, safety, packing, transportation, and storage constraints. These first three parts will help you know how to follow pre-conception practices that must be followed before, during, and after utilising the product.

Section five contains technical information about the rope charger controller, such as its functions, features, and applications, as well as technical specifications, and a block diagram of the controller's internal architecture, including the communication protocol, interface, and functions. Describe how to set up and integrate the controller with additional components and mechanical dimensions that will help users understand the installation.

Section six describes the interpretation of visual indications on chargers, including LED status and meaning, as well as information about the status on display during usage.

Finally, the appendix section included an abbreviation and glossary as well as the company's help desk and contact information.

WARNING!	Risk caused by inappropriate use!
	<p>Any unconventional use and/or different operation of the product can lead to hazardous situations.</p> <ul style="list-style-type: none"> • Only use the product in a conventional manner.

4.1 Limitation

The product is intended for use in an operational environment. It should not be used in hostile or explosive conditions.

The operator should consult local safety authorities and safety representatives before performing tasks in hazardous areas or in similar circumstances.

4.2 Alteration and Restoration of the Product/System

To prevent risks and make sure optimal performance, no alterations, attachments, or restoration of the product are permitted without explicit authorisation of Bacancy Systems PVT LTD.

5. Structure and Function



Figure 2 Rope Charger Controller

Bacancy's Rope Charger Controller is a customised solution that helps in the development of a complete portable AC charger for electric vehicles. It has one Type-2 connector (IEC 62196-2). It is an "all-in-one" device with integrated charging components such as a TFT display and an LED module.

The user can monitor the charging state using the display, which provides information such as set current, battery charging status, kilowatt-hour, watt, temperature, voltage, charging hours, and fault indicator. In addition, the LED module allows the user to monitor charging status and set current and time delays.

5.1 Overview

5.1.1 Feature

List of Feature

Earth Fault Detection.

Configurable Current and Time Delay.

RGB LED Indication for the Presence of Input Supply, Fault Indicator, and State of Charge.

Onboard Class-1 Energy Metering.

Surge Protection.

5.1.2 Application

List of Applications

EV Potable Charger

5.2 Function

5.2.1 Technical Specification

Product Properties	
Product Type	Rope Charger Controller
Product Family	AC Charger Controller
Electrical Properties	
Input Voltage	230 V AC \pm 10% Single Phase
Input Connection	P+N+PE
Frequency	50 or 60 Hz
Maximum Output Current and Power	3.3kW, Current Limit Set Up To:7A, 8A, 10A, 13A, 16A 7.4 kW, Current Limit Set Up To: 7A, 10A, 15A, 18A, 24A, 32A
Interface	
Display Protocol	SPI
Ambient Condition	
Degree of Protection	IP00
Operating Temperature	-20°C to +60°C
Storage / Transport Temperature	-25°C to +70°C
Permissible Humidity	5 to 95%
Connector	
Connector Type	Type-2
Number of Connectors	1
Mechanical Properties	
Dimension	154.99 (L) X 75.01 (B) mm
Weight	204 g (Controller & Mother Card)
Standards	
IS17017, IEC/EN 61000 and IEC61851	
Support	
Addon Board Support	LED Module & 1.8" TFT Display Module
Internal Support	Buzzer
External Support	NTC Thermistor, RCD & PT1000 for Temperature Sensor
Safety	
Over current, Over voltage, Under voltage, Short circuit protection, and Earth protection	

5.2.2 Block Diagram

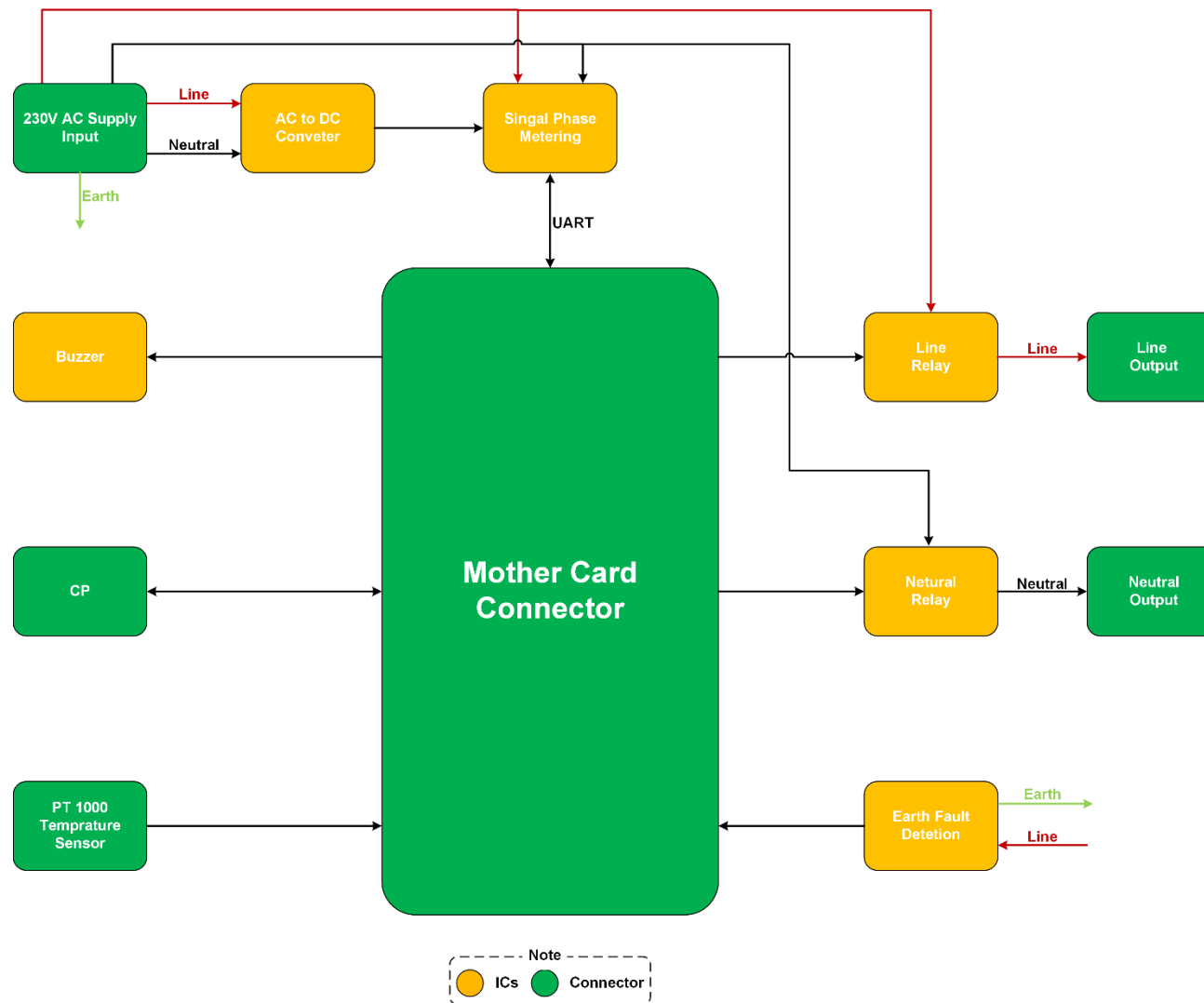

5.2.3 The Connector Interface

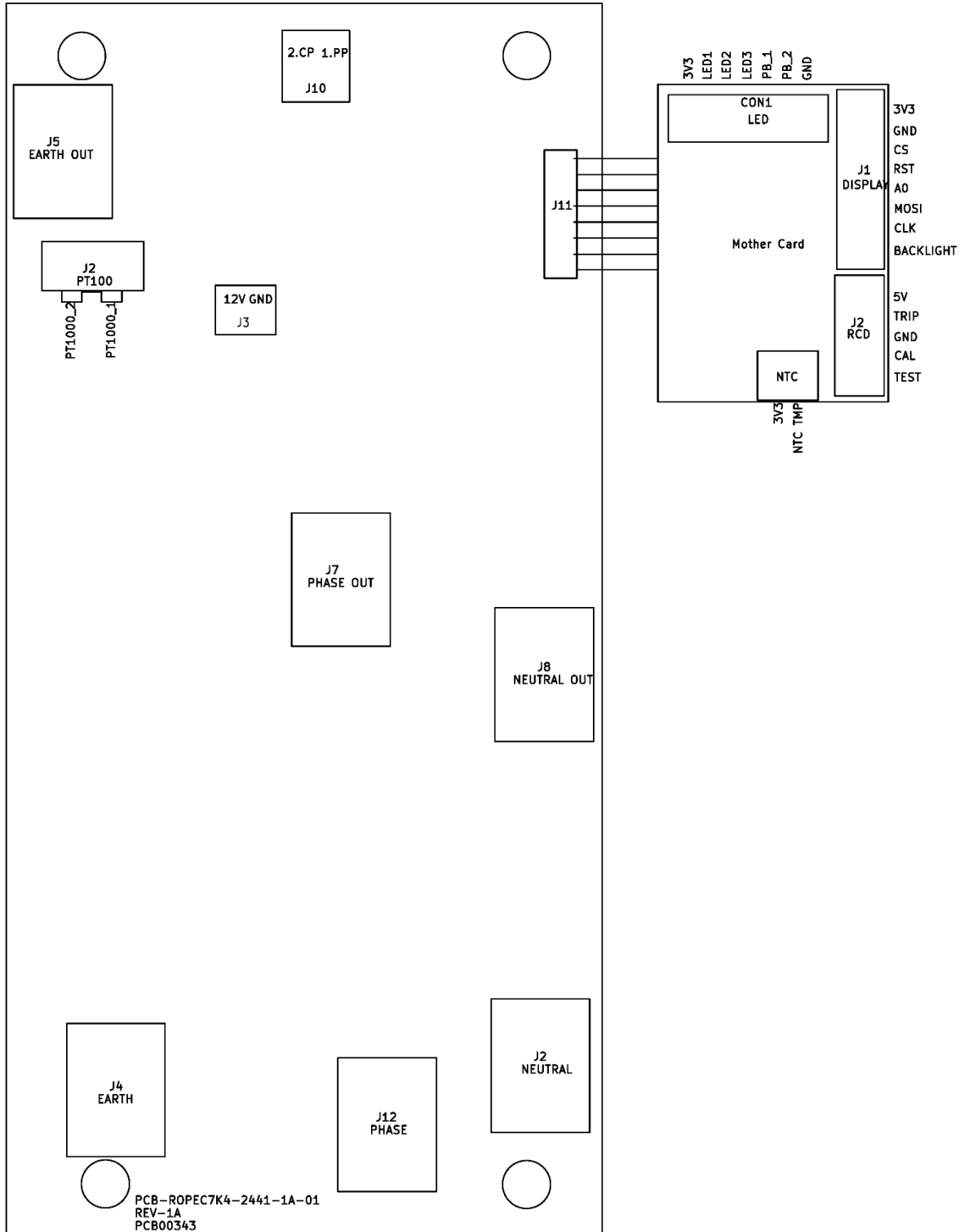

5.2.4 Pin Configuration

5.2.4.1 Controller

Table 2 Input Power Supply

No.	Connector	Pin	Signal Name	Description
1	J12	1	Phase	Input Phase Supply
2	J2	1	Neutral	Input Neutral Supply
3	J4	1	Earth	Input Earth Supply

Table 3 Output Power Supply

No.	Connector	Pin	Signal Name	Description
1	J7	1	Phase	Output Phase Supply
2	J8	1	Neutral	Output Neutral Supply
3	J5	1	Earth	Output Earth Supply

Table 4 Communication Channel

No.	Connector	Pin	Signal Name	Description
1	J10	1	PP	Proximity Pilot
2		2	CP	Control Pilot

Table 5 PT1000 Temperature Sensor

No.	Connector	Pin	Signal Name	Description
1	J2	1	PT1000_1	Temperature Sensor 1
2		2	PT1000_2	Temperature Sensor 2

Table 6 12 VDC Power Output Supply

No.	Connector	Pin	Signal Name	Description
1	J3	1	12V	12 VDC Power Output Supply
2		2	GND	Ground

5.2.4.2 Mother Card

Table 7 RGB LED Module Connection

No.	Connector	Pin	Signal Name	Description
1	CON1	1	3.3V	3.3 V Output Supply
2		2	LED1	LED 1 (Blue)
3		3	LED2	LED 2 (Green)
4		4	LED3	LED 3 (Red)
5		5	PB_1	Push Button 1
6		6	PB_2	Push Button 2
7		7	GND	Ground

Table 8 NTC Temperature Sensor Connection

No.	Connector	Pin	Signal Name	Description
1	NTC	1	3V3	3.3 V Output Supply
2		2	NTC Temp	NTC Temperature Sensor

Table 9 TFT 1.8" Display Module Connection

No.	Connector	Pin	Signal Name	Description
1	J1	1	3V3	3.3 V Output Supply
2		2	GND	Ground
3		3	CS	Chip Select
4		4	RST	Reset
5		5	AO	Data & Command Enabled
6		6	MOSI	Master Out Slave In
7		7	CLK	Clock
8		8	BACKLIGHT	LED

Table 10 RCD Connection

No.	Connector	Pin	Signal Name	Description
1	J2	1	5 V	3.3 V Output Supply
2		2	Trip	Trip
3		3	GND	Ground
4		4	CAL	Calibration
5		5	Test	Test

5.2.4.3 RGB LED Module

Table 11 RGB LED Connection with Mother Card

No.	Connector	Pin	Signal Name	Description
1	CON1	1	3.3V	3.3 V Output Supply
2		2	LED1	LED 1 (Blue)
3		3	LED2	LED 2 (Green)
4		4	LED3	LED 3 (Red)
5		5	PB_1	Push Button 1
6		6	PB_2	Push Button 2
7		7	GND	Ground

5.2.4.4 RGB LED Strip Module

Table 12 RGB LED Strip Module Connection with Mother Card

No.	Connector	Pin	Signal Name	Description
1	CON1	1	3.3V	3.3 V Output Supply
2		2	LED1	LED 1 (Blue)
3		3	LED2	LED 2 (Green)
4		4	LED3	LED 3 (Red)
5		5	PB_1	Push Button 1
6		6	PB_2	Push Button 2
7		7	GND	Ground

Table 13 RGB LED Strip Connection

No.	Connector	Pin	Signal Name	Description
1	CON2	1	Blue	Blue LED
2		2	Green	Green LED
3		3	Red	Red LED
4		4	VCC	Power Supply
5		5	G	Ground

5.2.5 Mechanical Diagram

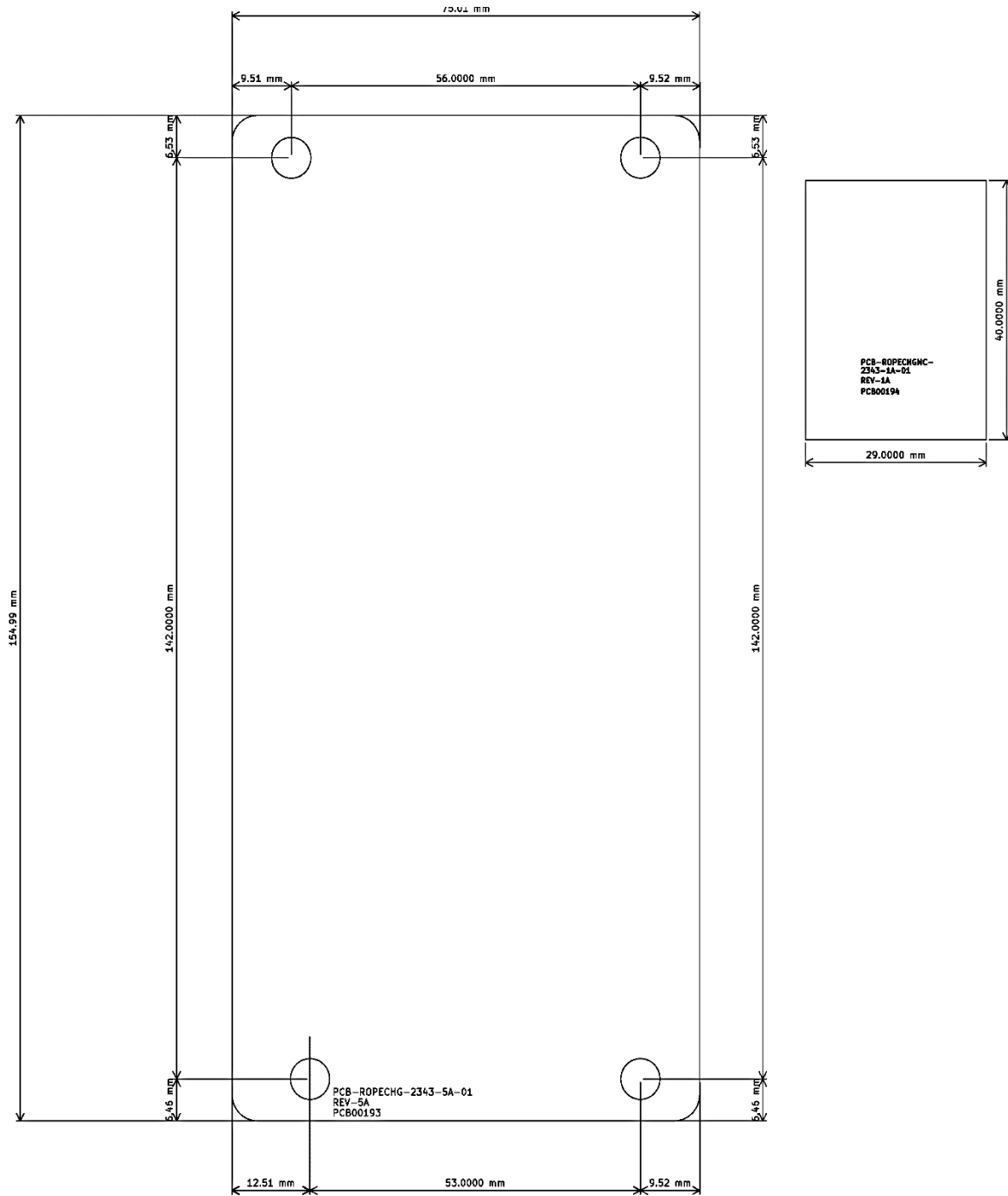

5.2.6 LED Module

The user can connect the LED module to the Rope charging controller. There are two types of LED modules: RGB LED modules and RGB LED strip modules, which allow you to change the power current and time delay using the module's switch.

1. RGB LED Module

This variant of the LED module has an in-built RGB LED with the module, which requires a 3.3 V power supply.

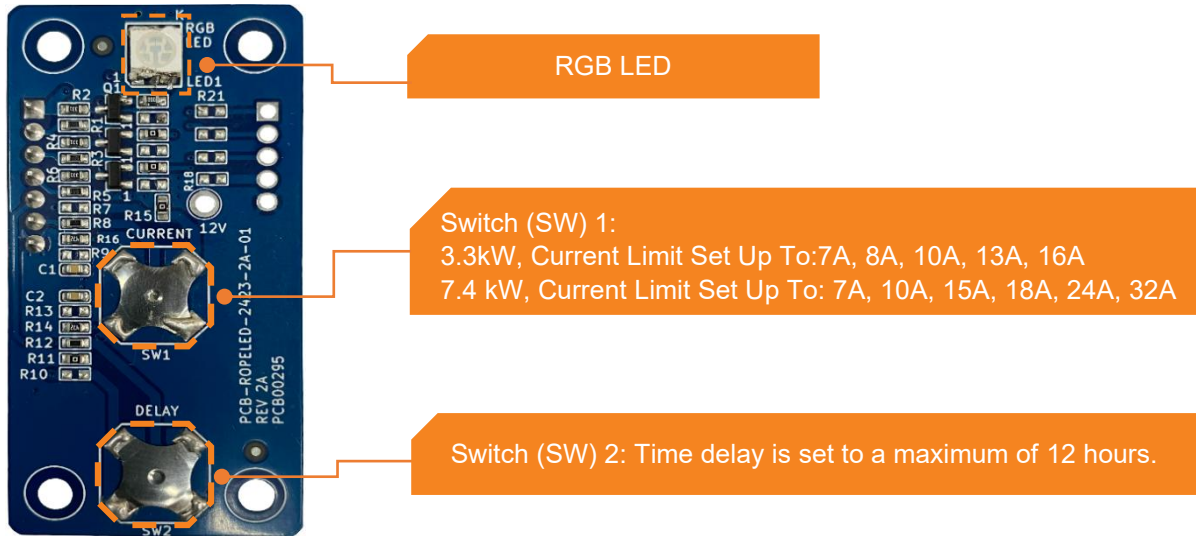

Figure 3 Switches 1 and 2 are for Setting the Current and Time Delay for LED Module.

2. RGB LED Strip Module

Another variant of the LED module has the external RGB LED strip connection with the module, which requires a 12 V power supply.

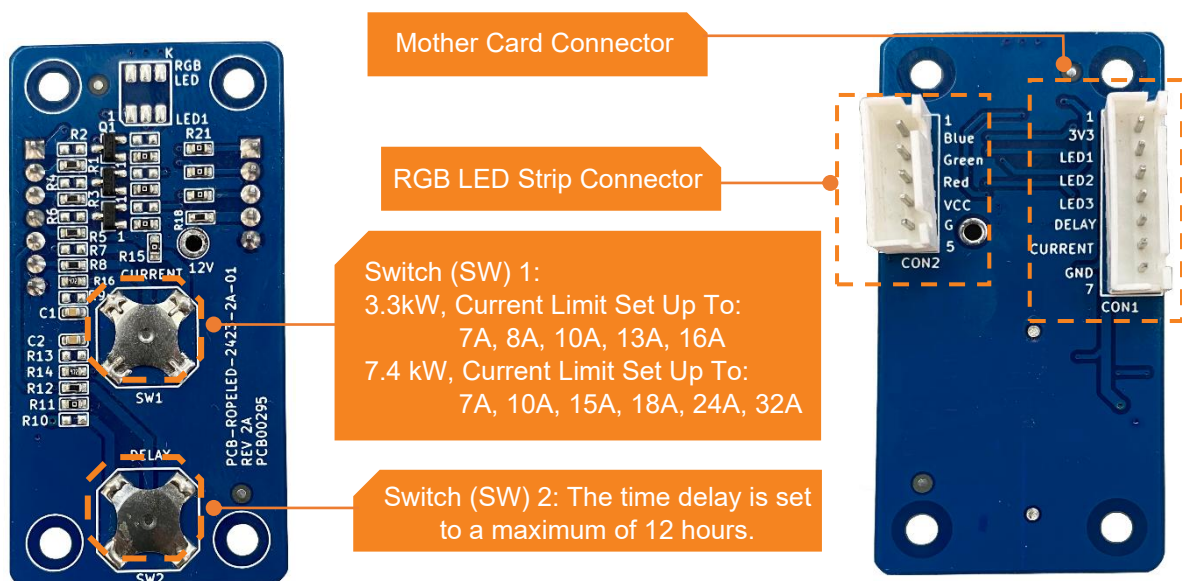





Figure 5 Switches 1 and 2 are for Setting the Current and Time Delay.

Figure 5 RGB LED Strip Connector.

6. Interpretation of Visual Indication

6.1 LED Status

Table 14 LED Status and Its Meaning

No.	LED Colour	LED Status	EV Charging State
1	Blue 	Blinking	Available
2	Blue 	Steady	Preparing
3	Green 	Steady	Charging
4	Red 	Steady	Fault

6.2 Fault Status

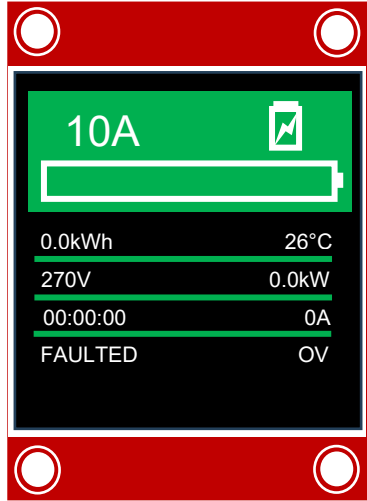
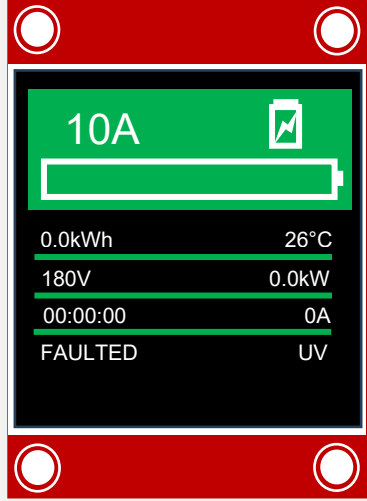
No.	Fault Status	Description	Display
1	Over Voltage (OV)	If the voltage exceeds 270 V, "OV" will be displayed, and the buzzer will beep.	
2	Under Voltage (UV)	If the voltage is lower than 180 V, "UV" will be displayed, and a buzzer will beep.	

No.	Fault Status	Description	Display
3	Over Current (OC)	If the current exceeds the selected current limit by +1A, "OC" will be displayed, and the buzzer will beep.	
4	Under Current (UC)	If the EV is in charging mode and the load current is less than 0.5A, "UC" will be displayed, and the buzzer will beep.	
5	High Temperature (HT)	If the temperature exceeds 90°C, "HT" will be displayed, and the buzzer will beep.	

No.	Fault Status	Description	Display
6	CP Fault (CP)	If the EV is not in a defined condition, "CP" will be displayed, and the buzzer will beep.	
7	Earth Fault (E)	If the earth is not connected, "ET" will be shown, and the buzzer will beep.	
8	Leakage Current (RCD)	If an RCD is connected and the trip pin is high, the "RCD" displays, and the buzzer will beep.	

7. Fault Management

The rope charger controller is facilitated with a fault management system to detect abnormal operating conditions and ensure safe charging operation. In addition, the controller can take appropriate actions based on the fault type, including stopping charging and initiating recovery procedure mode.

Fault recovery behaviour is categorised as either:

- **Manual Recovery:** User intervention is required to resume charging.
- **Automatic Recovery:** Charging resumes automatically once normal operating conditions are restored.

Table 15 Fault Type and Recovery.

Fault Type	Detection Criteria	Time	Recovery Condition	Recovery Mode
Overcurrent	Parameter exceeds configured limit	Active: ≥35 s	Unplugging the gun is required	Manual
Undercurrent	Parameter below configured limit	Active: ≥35 s	Unplugging the gun is required	Manual
RCD (Leakage)	Residual current exceeds threshold	Active: ≥35 s	Unplugging the gun is required	Manual
Earth Fault	Protective earth continuity fault detected	Recovery Time: 35 s	Parameter is restored within configured limits	Automatic
Overvoltage	Supply parameter exceeds limit	Recovery Time: 35 s	Parameter is restored within configured limits	Automatic
Undervoltage	Supply parameter below the limit	Recovery Time: 35 s	Parameter is restored within configured limits	Automatic
High Temperature	Thermal parameter exceeds limit	Recovery Time: 35 s	Parameter is restored within configured limits	Automatic
CP Fault	Control Pilot signal out of a valid state	Recovery Time: 35 s	Signal is restored to a valid operational state	Automatic

7.1 Recovery Mode

1 When a manual recovery fault is detected:

- The charging process will stop immediately.
- The charger cannot resume operation automatically.
- The user must unplug and plug-in the gun to clear the fault.

2 When an automatic recovery fault is detected:

- The Charging process will be suspended.
- The charger continuously monitors system conditions.
- The charging process will automatically resume once the condition returns to the acceptable range.

MANDATORY	User Information
	<ul style="list-style-type: none"> • Fault conditions are indicated via the charger status indicators or display. • Ensure proper electrical supply conditions • Verify the correct connection of the charging cable • Avoid operating the charger under abnormal environmental conditions

NOTE!	Fault Management System
	<ul style="list-style-type: none"> • Detection thresholds and recovery timing are pre-configured and may vary depending on system configuration. • The fault management system is focused on ensuring: <ul style="list-style-type: none"> – User safety – Vehicle protection – Reliable charger operation

8. Appendix

8.1 Abbreviations and Glossary

AC	<i>Alternating current, is a type of electrical current in which the current repeatedly changes direction.</i>
CON	<i>Connector</i>
CP	<i>Control Pilot is a communication line used to negotiate charging levels between the car and the EVSE, and it can be manipulated by the vehicle to initiate charging and carry other information.</i>
DC	<i>Direct current (DC) is a one-directional flow of electric charge.</i>
EV	<i>An EV is defined as a vehicle that can be powered by an electric motor that draws electricity from a battery and is capable of being charged from an external source.</i>
GND	<i>GND stands for Ground. A common or shared return route of electrical current to the power source that enables the completion of the circuit refers to the ground in both electrical and electronic circuits.</i>
Hz	<i>Hertz, the SI unit of frequency, is equal to one cycle per second.</i>
IC	<i>An integrated circuit (IC), sometimes called a chip, microchip, or microelectronic circuit, is a semiconductor wafer on which thousands or millions of tiny resistors, capacitors, diodes, and transistors are fabricated.</i>
IEC 62196-2	<i>IEC 62196 Plugs, socket-outlets, vehicle connectors, and vehicle inlets: Conductive charging of electric vehicles is a series of international standards that define requirements and tests for plugs, socket-outlets, vehicle connectors, and vehicle inlets for conductive charging of electric vehicles and are maintained by the technical subcommittee SC 23H, "Plugs, socket-outlets, and Couplers for Industrial and Similar Applications, and for Electric Vehicles," of the International Electrotechnical Commission (IEC).</i>
IEC/EN 61000	<i>IEC/EN 61000 IEC/EN 61000-3-2 deals with the limitation of harmonic currents that are supplied from the mains network with a voltage not less than 220V and a current up to and including 16A per phase.</i>
IEC61851	<i>IEC 61851 is an international standard for electric vehicle conductive charging systems.</i>
IS17017	<i>IS 17017 is the key electric vehicle charging standard in India.</i>

<i>kW</i>	<i>kW is a kilowatt. kW is used to represent the actual power that carries out the work.</i>
<i>kWh</i>	<i>A kilowatt-hour is a non-SI unit of energy equal to 3.6 megajoules in SI units which is the energy delivered by one kilowatt of power for one hour. Kilowatt-hours are a common billing unit for electrical energy supplied by electric utilities.</i>
<i>LED</i>	<i>A light-emitting diode (LED) is a semiconductor device that emits light when current flows through it.</i>
<i>mm</i>	<i>The millimetre is a unit of length in the International System of Units (SI), equal to one thousandth of a metre.</i>
<i>NTC</i>	<i>NTC stands for “Negative Temperature Coefficient”. NTC thermistors are resistors with a negative temperature coefficient, which means that the resistance decreases with increasing temperature.</i>
<i>P+N+PE</i>	<i>A single-phase system is an electrical power distribution system that consists of one conductor carrying alternating current (AC) power, a neutral conductor, and a protective earth conductor.</i>
<i>PE</i>	<i>A protective earth connection, earth ground, or safety ground uses a protective conductor to safely direct a fault current into the earth and away from a human being in contact.</i>
<i>PP</i>	<i>Proximity Pilot, aka “plug present,” provides a signal to the vehicle’s control system so it can prevent movement while connected to the electric vehicle supply equipment (EVSE, i.e., the charging station) and signals the latch release button to the vehicle.</i>
<i>PT1000</i>	<i>The first part of the name Pt1000, “Pt”, is the chemical symbol for Platinum and this shows that the sensor is Platinum-based. The second part, 1000, indicates the nominal resistance of the sensor at 0°C.</i>
<i>RDC</i>	<i>Residual Direct Current</i>
<i>RGB</i>	<i>Red, Green, Blue</i>
<i>SPI</i>	<i>Serial Peripheral Interface (SPI) is a de facto standard for synchronous serial communication, used primarily in embedded systems for short distance wired communication between integrated circuits.</i>
<i>TFT</i>	<i>A Thin Film Transistor is a display screen technique used in LCD (liquid crystal display).</i>

<i>Type-2 Connector</i>	<i>The IEC 62196 Type 2 connector is used for charging electric vehicles, mainly within Europe, as it was declared standard by the EU.</i>
<i>UART</i>	<i>A Universal Asynchronous Receiver-Transmitter is a protocol for asynchronous serial communication in which the data format and transmission speeds are configurable.</i>

 **Bacancy Systems PVT LTD,**
15-16, Times Corporate Park,
Near Thaltej-Shilaj Road,
Opp. Copper Stone Flats,
Thaltej, Ahmedabad,
Gujarat, India, 380059

 www.bacancysystems.com

 systems@bacancysystems.com

 +91 90160 28817

 **Helpdesk:** <https://bacancy.freshdesk.com/a/dashboard/default>