

User Guide

Electric Vehicle Communication Controller (EVCC)

Please completely read this document and the contained safety instructions and note all given information before usage.

Please maintain the confidentiality of this user guide. It is intended solely for usage by people professionally associated with the product. If you are not the intended recipient, you may not disclose or use the information in this documentation. The information does not constitute an offer or solicitation to buy or sale of any security.

This user guide's text and illustrations have been meticulously crafted. However, we may not be held accountable for any discrepancies or failure consequences.

Some company and label names are protected by a label, a patent, or a trademark.

Copyright ©

Address: Bacancy Systems PVT LTD,
15-16, Times Corporate Park,
Near Thaltej-Shilaj Road,
Opp. Copper Stone Flats,
Thaltej, Ahmedabad,
Gujarat, India, 380059

Website: www.bacancysystems.com

Email: systems@bacancysystems.com

Phone: +91 90160 28817

All rights reserved, including disposal, exploitation, reproduction, editing, distribution, as well as and utilisation for intellectual property rights.

Liability

The given data is primarily for product description reasons and should not be considered a guaranteed characteristic unless specifically stated in the contract. All rights are retained with regard to the content of this documentation and the availability of the product.

DISCLAIMER

The product, product data and any of its specifications are subject to change without notice. Bacancy Systems PVT LTD, its employees, and all persons acting on its behalf shall not be liable for any errors, inaccuracies, or incompleteness that occur if the methodology contained herein or in any other revelation of the product is not followed. The product specifications alter or amend neither the terms nor conditions of purchase nor the warranty expressed therein.

Bacancy Systems PVT LTD offers no warranty, representation, or guarantee other than as set forth in the terms and conditions of purchase. To the maximum extent permitted by applicable law.

Bacancy Systems PVT LTD, Disclaims

- (i). Any and all liability arising out of the application or use of any product.
- (ii). Any and all liability, including without limitation special, consequential or incidental damages
- (iii). Any and all implied warranties, including those of merchantability, fitness for a specific purpose, and non-infringement.

The information provided in user guide and/or specifications may differ from actual results in different circumstances, and efficiency may change over time. Statements on a product's appropriateness for a certain application are based on Bacancy Systems PVT LTD's understanding of standard demands that are frequently put on the products of Bacancy Systems LLP. The customer should determine whether a given Bacancy Systems PVT LTD product with the features mentioned in the product specification is appropriate for use in a specific application.

The product shown herein is not designed for use in lifesaving or life-sustaining applications unless otherwise expressly indicated. Customers who utilise or sell Bacancy Systems PVT LTD products that are not explicitly intended for such applications do so solely at their own risk.

This user guide is intended to improve the operator's efficiency throughout the procedure and does not entirely absolve them of responsibility.

Change Record

Rev. No.	Date	Details	Revised By	Approved By
1	03/04/2026	Initial Release	Rajkumar Patel	Vivek Vasavada
2	01/05/2026	Revised Email Address	Rajkumar Patel	Vivek Vasavada

Table of Contents

1. About this Document.....	9
1.1 Information on the User Guide.....	9
1.2 Limitations of Liability.....	9
2. Safety.....	10
2.1 Safety Graphical Pictogram or Symbol	10
2.2 Safety Instructions and Warnings	11
2.2.1 General Safety.....	11
2.2.2 Electrical Safety	11
2.2.3 Installation Safety	12
2.2.4 Operational Safety	12
2.2.5 Maintenance and Service	13
2.2.6 Fire Protection	13
2.3 The Responsibility of the Operator.....	14
2.4 Person in Charge of Operations	14
2.5 In an occurrence of Danger or an Accident.....	14
3. Packaging, Transport and Storage.....	15
3.1 Inspection, Packaging, and Transport.....	15
3.2 Transport.....	15
3.3 Storage.....	15
4. Intended Use	16
4.1 Limitation	16
4.2 Alteration and Restoration of the Product/System.....	16
5. Structure and Function.....	17
5.1 Overview	17
5.1.1 Feature	17
5.1.2 Application	17
5.2 Function.....	18
5.2.1 Technical Specification	18
5.2.2 Block Diagram	18
5.2.3 Mechanical Drawing	19
5.2.4 Pin Configuration	20
A. J1 Connector (30-Pin).....	20
B. J2 Connector (18-Pin).....	22
6. Cable Management	24
6.1 Prerequisites	24

6.2	Technical Requirements	24
A.	Wire Specification	24
B.	Strip Length.....	24
C.	Crimp Quality	24
D.	Reference	24
6.3	Procedure.....	25
6.3.1	Wire and Terminal	25
6.3.2	Connector.....	27
6.3.3	Inspection & Quality Check.....	30
6.3.4	Rework Procedure.....	31
Appendix	33
Appendix A	Mechanical Design	33
Appendix A1	J1 30-Pin Connector.....	34
Appendix A2	J2 18-Pin Connector.....	35
Appendix A3	Terminal	36
Appendix B	Abbreviations and Glossary	38

List of Figures

Figure 1 Safety Instruction	10
Figure 2 Electric Vehicle Communication Controller (EVCC).....	17
Figure 3 Block Diagram of EVCC with EV Charging Subsystems.....	18
Figure 4 J1 Connector (30-Pin).....	20
Figure 5 J2 Connector (18-Pin).....	22
Figure 6 Load the terminal.	25
Figure 7 Insert stripped wire.....	25
Figure 8 Press the crimp tool.	26
Figure 9 Remove crimp wire.	26
Figure 10 Inspect the wire and terminal.....	26
Figure 11 Pre-open position of the secondary lock.....	27
Figure 12 Position of the terminal's polarisation ears.	27
Figure 13 Insert the terminal in a cavity.....	27
Figure 14 Tug test to confirm locking.	28
Figure 15 Wires in the middle row.	28
Figure 16 wires in the outer rows.	28
Figure 17 Insert the secondary lock.	29
Figure 18 Closed secondary lock.	29
Figure 19 First tie point at 50mm.....	30
Figure 20 Secure harness cable.	30
Figure 21 Open the secondary lock.....	31
Figure 22 Position of the terminal removal tool.....	31
Figure 23 Insert the terminal removal tool in the cavity.....	32
Figure 24 Pull the wire to remove the terminal.	32
Figure 25 Replace the terminal if damaged.....	32

List of Tables

Table 1 Safety Graphical Pictogram or Symbol	10
Table 2 J1 Connector (30-Pin).	20
Table 3 J2 Connector (18-Pin).	22
Table 4 Tools and Equipment for Cable Management.....	24

1. About this Document

1.1 Information on the User Guide

This user guide contains basic information to be considered in the utilisation of the product. A precondition for safe working is the observance of all stated safety instructions and directions. Therefore, this user guide should be read and applied without fail by any person assigned to the installation and operating procedures of the product or system.

This user guide is part of the product, and the case may have to be passed to third parties or the following owners. It must be permanently kept at the usage site and be available for the operating personnel who are responsible for the installation of this product or system.

We are eager to ensure the comprehensiveness, relevance, and up-to-dateness of this user guide. It may become essential to make spontaneous changes to the product and its operation, which may not align with this manual, to maintain our technical advancement. In that case, Bacancy Systems PVT LTD will provide you with a new manual. We exclude liability for disturbances, failures, and resulting damages.

The illustrations in this user guide will provide a better understanding. It can occur that illustrations are not drawn to scale or deviate somewhat from the original.

1.2 Limitations of Liability

All statements and remarks in this user guide have been aggregated with consideration of current standards, laws, and regulations, the state of technology, as well as our extensive knowledge, long-time expertise, and experience. In special models, due to demands for additional order options or the latest technical alterations, the actual scope of delivery can differ from the explanations and elaborations described here.

The manufacturer excludes any liability for damages caused by:

- Inappropriate assembling and installation.
- Non-observance of the user manual.
- Non-intended and improper use.
- Use beyond operation limits.
- Deployment of insufficiently qualified and trained personnel.
- Use of unauthorised spare parts and accessories.

2. Safety

The safety directions, cautions, warnings, and notices are stated here. Moreover, in this user guide's section, the following sections have to be followed to reduce potential health risks and prevent hazardous situations as per the ISO 45001:2018 standard for occupational health and safety.

2.1 Safety Graphical Pictogram or Symbol

These prescribe safety signs for the purposes of accident prevention, fire protection, health hazard information, and emergency evacuation as per the ISO 7010:2019 standard for graphical symbols, safety colours, and registered safety signs.

The safety instructions are structured as follows:

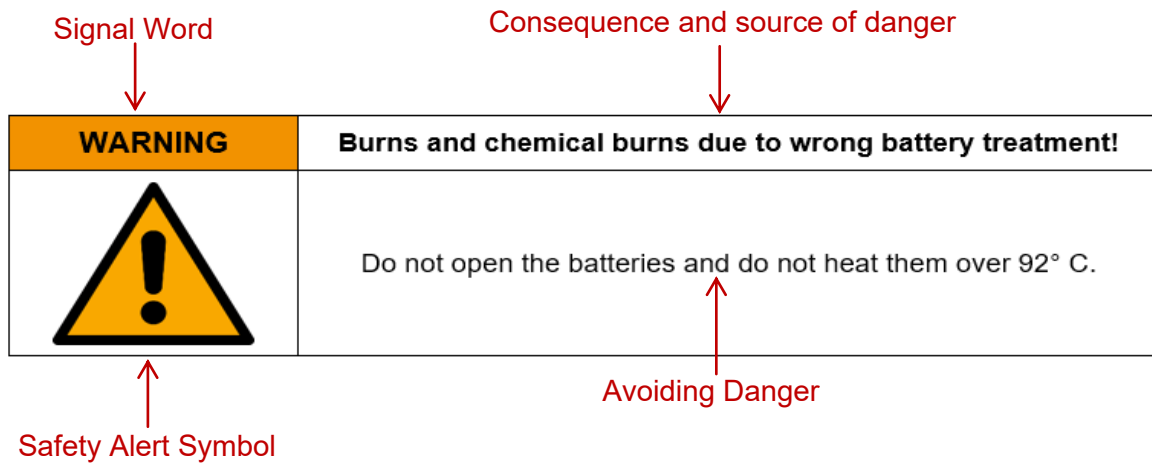





Figure 1 Safety Instruction

Table 1 Safety Graphical Pictogram or Symbol

Pictogram / Symbol	Signal Word	Meaning
	DANGER!	In case of non-compliance with this safety instruction, death or serious injury will occur.
	WARNING!	In case of non-compliance with this safety instruction, death or serious injury can occur.
	CAUTION!	In case of non-compliance with this safety instruction, a minor or moderate injury can occur.
	NOTICE!	In case of non-compliance with this safety instruction, material damage can occur.
	NOTE!	Useful notice or tip on the products or system's easy operation.

2.2 Safety Instructions and Warnings

2.2.1 General Safety



The Electric Vehicle Communication Controller (EVCC) is designed for integration into EV charging systems. It must be installed, operated, and maintained only in accordance with this documentation.

Failure to follow these safety instructions may result in:



- Electric shock
- Fire or explosion
- Personal Injury
- Equipment Damage

Only qualified personnel shall perform installation, operation, and maintenance.



2.2.2 Electrical Safety

Risk of Electric Shock	
DANGER	
	The EVCC contains voltages. Direct contact with live parts can result in serious injury or death.
MANDATORY	
	<ul style="list-style-type: none"> • Disconnect all power sources before installation or servicing. • Verify absence of voltage before handling components. • Ensure proper protective earth (PE) connection before operation. • Use insulated tools and appropriate personal protective equipment (PPE).
PROHIBITED	
	<ul style="list-style-type: none"> • Working on live circuits. • Bypassing grounding or protective devices



2.2.3 Installation Safety

Equipment	
WARNING	
	The EVCC is provided as complete equipment in a close enclosure and must be installed in one.
MANDATORY	
	<ul style="list-style-type: none"> Install in a clean, dry, and well-ventilated environment. Provide adequate mechanical protection and thermal management. Maintain proper clearance and creepage distances. Secure all electrical connections before energising
PROHIBITED	
	Installation in: <ul style="list-style-type: none"> High humidity or wet conditions. Dusty or corrosive environments. Areas with flammable gases or materials. Locations exposed to heat, sparks, or open flames.



2.2.4 Operational Safety

Safe Operation	
CAUTION	
	<ul style="list-style-type: none"> Operate only within specified ratings and conditions. Monitor for abnormal conditions such as overheating, noise, or communication faults.
MANDATORY	
	<ul style="list-style-type: none"> Read and understand the user guide before operation. Disconnect power immediately in case of malfunction.
PROHIBITED	
	<ul style="list-style-type: none"> Wearing metallic items (Rings, Watches, Bracelets, Necklaces). Performing hot work near batteries. Using high-pressure water for cleaning.

2.2.5 Maintenance and Service

Risk Dring Maintenance	
WARNING	
	Improper servicing may result in injury or equipment damage.
MANDATORY	
	<ul style="list-style-type: none"> Maintenance must be performed by qualified personnel only. Isolate and secure all power sources before servicing. Use insulated and ESD-safe tools when handling electronics components. Use only manufacturer-approved components.
PROHIBITED	
	<ul style="list-style-type: none"> Unauthorised modification or disassembly. Use of non-approved or incompatible parts.

2.2.6 Fire Protection

Fire Hazard	
WARNING	
	Electrical faults may lead to fire.
FIRE	
	<ul style="list-style-type: none"> Use dry powder or CO₂ fire extinguishers. Ensure appropriate upstream protection.
PROHIBITED	
	<ul style="list-style-type: none"> Unauthorised modification or disassembly. Use of water on electrical equipment.

2.3 The Responsibility of the Operator

The product is associated with industrial safety standards. However, the operator who is installing or operating the product is liable for the legal responsibilities for operational safety. In addition to the operational safety instructions in this manual, the safety, accident prevention, and environmental protection regulations valid for the operational area of the product shall be followed.

2.4 Person in Charge of Operations

WARNING!	Risk of injury caused by a lack of an adequate qualification!
	Inappropriate handling of the product can lead to severe personal injuries and material damage.

In this manual, the following qualifications are specified:

Instructed Person	An instructed person is someone who has been instructed by the operator or manufacturer on the given tasks and potential hazards in the event of incorrect behaviour, as well as being semi-skilled and knowledgeable about the necessary safety procedures and safeguards.
Qualified Specialised Professional	Qualified specialised professionals are individuals who are knowledgeable with the assembly, commissioning, and operation of the product and process qualifications related to their work. The specialised individual is able to recognise hazards and prevent potential hazards because of their professional training, knowledge, and experience, as well as their understanding of the appropriate regulations.

2.5 In an occurrence of Danger or an Accident

Preventive Measures:

- Always be prepared for accidents or fires!
- Keep first-aid equipment (ambulance boxes, blankets, etc.) within easy reach.
- Inform personnel with accident alerting, first-aid, and emergency services.
- Keep clear access routes for emergency vehicles.

If the occurrence happens, follow these steps:

- Turn off the product immediately.
- Implement first-aid procedures.
- Get people out of hazardous areas.
- Inform the appropriate person at the usage spot.
- Contact a doctor and/or the fire department.

3. Packaging, Transport and Storage

3.1 Inspection, Packaging, and Transport

The products have been properly secured to ensure sufficient safeguarding during shipment. Please scrutinise the delivered products for overall quality and transportation problems as soon as possible.

In the instance of external shipment damage, proceed as follows:

- Do not accept delivery or accept it only on reserve.
- Issue a complaint.
- Do not use items that are obviously defective.

3.2 Transport

Always ensure that your equipment is transported in safe and appropriate containers while transporting it to the usage location or in the field.

Never transfer everything in an unplanned way in the vehicle. Hits and thrusts might seriously impair the product's functionality.

Always use the original packaging, transport containers, transport boxes, or equivalent packaging, whether transporting by train, aircraft, or ship. The container shields the goods from impacts and vibrations.

3.3 Storage

Strictly store the product in well-ventilated, dry spaces. During storage, keep it dry and leverage the original packaging if possible.

Avoid extreme heat fluctuations during storage. The initiation of water condensation can impair the product's operation.

When storing, keep in mind the temperature restrictions of the product. Please refer to the product's technical data for valid storage temperatures.

4. Intended Use

This user guide provides essential information for the safe and correct use of the Electric Vehicle Communication Controller (EVCC). It is intended to help users understand the product's technical characteristics, installation requirements, and operational behaviour. The document focuses primarily on the technical aspects of EVCC and presents the information in a structured manner using descriptive text, diagrams, and tables.

Sections 1 to 3 contain general information related to the document, including product liability, safety instructions, as well as packaging, transportation, and storage requirements. These sections outline the necessary precautions and recommended practices to be followed before, during, and after handling or using the product.

Section 5 provides detailed technical information about the EVCC, including its functions, features, applications, technical specifications, block diagram, mechanical diagrams, and electrical interfaces such as pin configurations.

Section 6 describes the cable management procedures, including prerequisites and technical requirements.

Finally, the appendix section includes information on p abbreviations and a glossary of terms, the mechanical design of the connector and terminal, along with details of the company's help desk and contact information.

WARNING!	Risk caused by inappropriate use!
	<p>Any unconventional use and/or different operation of the product can lead to hazardous situations.</p> <ul style="list-style-type: none"> • Only use the product in a conventional manner.

4.1 Limitation

The product is intended for use in an operational environment. It should not be used in hostile or explosive conditions.

The operator should consult local safety authorities and safety representatives before performing tasks in hazardous areas or in similar circumstances.

4.2 Alteration and Restoration of the Product/System

To prevent risks and make sure optimal performance, no alterations, attachments, or restoration of the product are permitted without explicit authorisation of Bacancy Systems PVT LTD.

5. Structure and Function

5.1 Overview

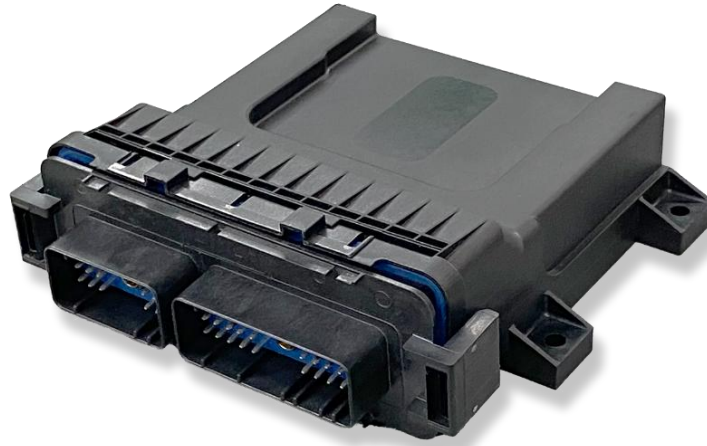

Figure 2 Electric Vehicle Communication Controller (EVCC).

Bacancy Systems' Electric Vehicle Communication Controller (EVCC) is designed to manage communication, safety, and power control during CCS2 charging. It works as the intermediate between the Charging Station (EVSE) and the Vehicle Control Unit (VCU).

The EVCC supports high-level communication such as ISO 15118 and DIN 70121 standards for charging communication protocols, SAE J1939 over dual CAN communications interfaces for VCU, and multiple digital and analog input output interfaces for monitoring key safety parameters such as Control Pilot (CP), Proximity Pilot (PP), Protective Earth (PE), interlocks, contactor feedback, and temperature sensor (PT1000). Moreover, the system offers an H-Bridge output for connector locking and control contactors for high-voltage DC+ and DC- power lines.

It is well-engineered with automotive-grade design, which includes functional safety compliance of ISO 26262 ASIL-B and IP69 protection that makes it highly suitable for electric buses and trucks, and other EV applications.

5.1.1 Feature

List of Feature

- Full support for CCS2 charging communication
- Automotive-grade design with functional safety support
- Built-in H-Bridge output for actuator control
- Integrated CP, PP, and PE interface
- Dual CAN interface for vehicle and subsystem communication

5.1.2 Application

List of Applications

- CCS2 Charging Vehicles, Electric Buses and Trucks and EV Powertrain Systems

5.2 Function

5.2.1 Technical Specification

Power Supply	
Input Voltage Range	12 VDC / 24 VDC
I/O Capabilities	
Digital Input	8 Channels
Digital Output	Low Current: 4 Channels (LED Indication) High Current: 2 Channels
H-Bridge Output	2
Temperature Input	4 Channels (PT1000)
Communication Interface	
Button Input	1
CAN Communication	2 Channels
Plug Interface	CP, PP and PE
Standards	
Charging Compliance	ISO 15118, DIN 70121
Functional Safety	ISO 26262 ASIL-B
Charging Protocol	CCS2
VCU Communication	SAE J1939
Mechanical	
IP Rating	IP69
Operating Temperature	-40°C to 85°C
Dimension	148 (L) X 154 (B) X 60 (H) mm

5.2.2 Block Diagram

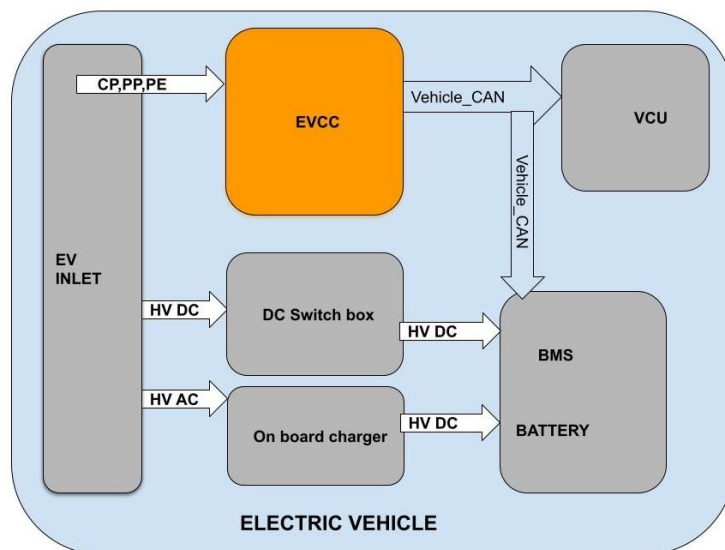
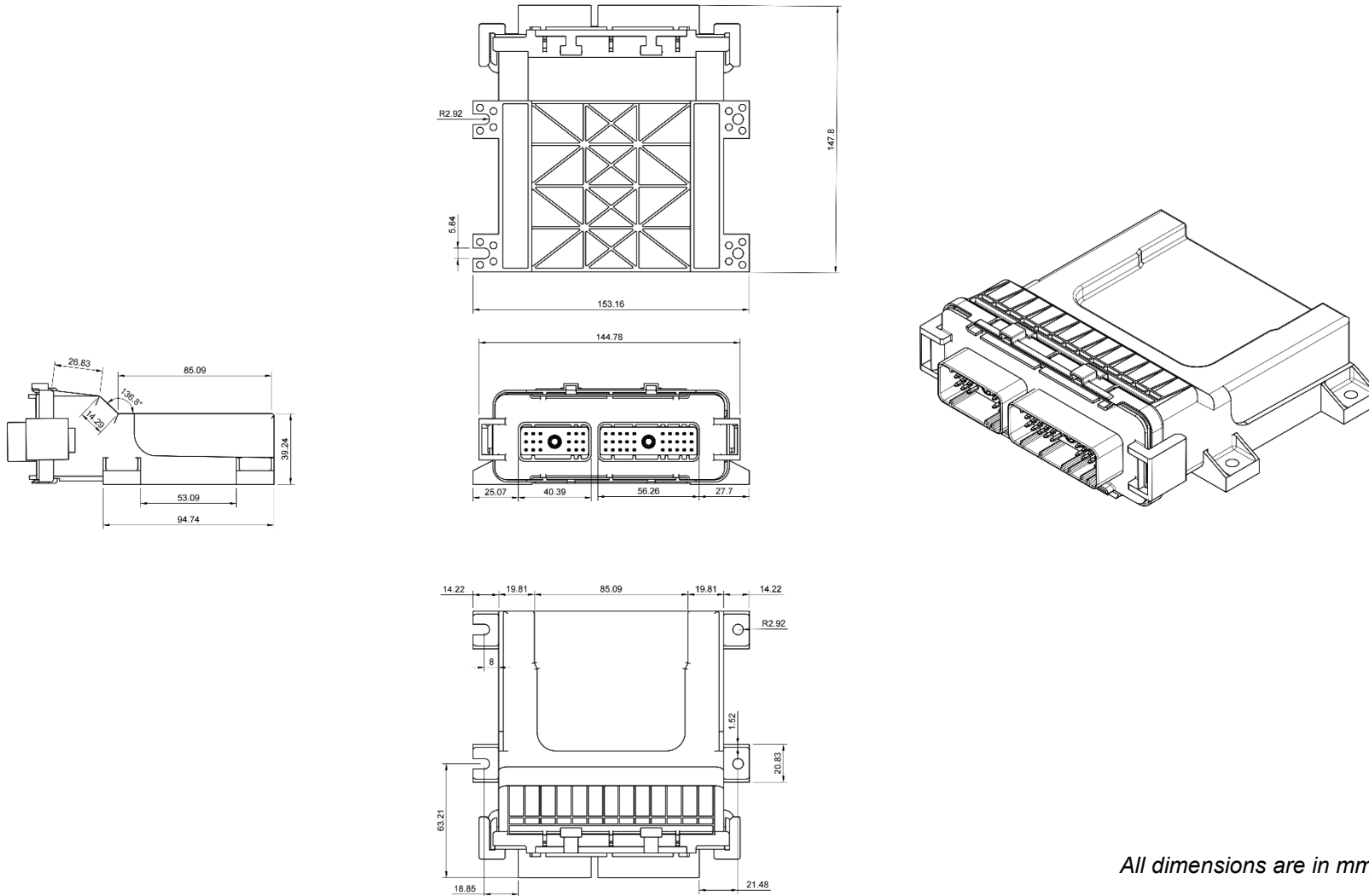

Figure 3 Block Diagram of EVCC with EV Charging Subsystems.

5.2.3 Mechanical Drawing



All dimensions are in mm.

5.2.4 Pin Configuration

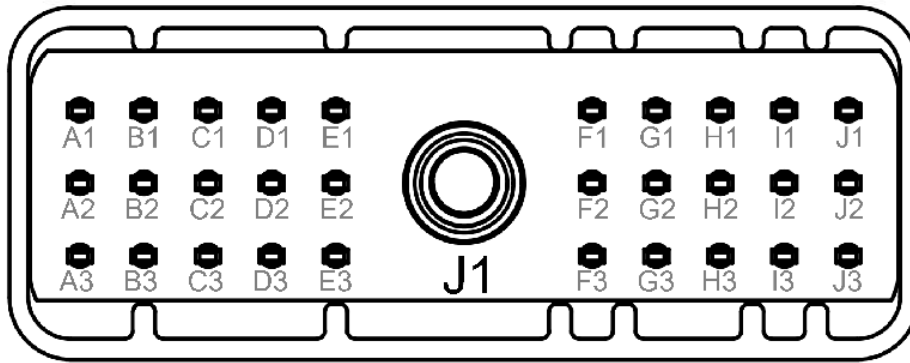

Figure 4 J1 Connector (30-Pin).

A. J1 Connector (30-Pin)

Table 2 J1 Connector (30-Pin).

Pin	Schematic Pin	Signal Name	Type of Signal	Description
J1	1	CP_1	Comm	Control Pilot: PWM signal to communicate allowed charging current and EV state.
J2	2	PP_1	Comm	Proximity pilot. Sends info to EV: cable type and max current rating.
J3	3	PE_1	Comm	Connection to earth for safety; shields HV lines.
I1	4	can_vehicle_p	Comm	Vehicle CAN High line.
I2	5	can_vehicle_p	Comm	Vehicle CAN High line.
I3	6	GND	Supply	Ground reference.
H1	7	can_vehicle_n	Comm	Vehicle CAN Low line.
H2	8	can_vehicle_n	Comm	Vehicle CAN Low line.
H3	9	GND	Supply	Ground reference.
G1	10	can_charger_p	Comm	Charger CAN High line.
G2	11	can_charger_p	Comm	Charger CAN High line.
G3	12	GND	Supply	Ground reference.
F1	13	can_charger_n	Comm	Charger CAN Low line.
F2	14	can_charger_n	Comm	Charger CAN Low line.
F3	15	GND	Supply	Ground reference.
E1	16	hvsw1_hs_1	Output	High-side control of HV Switch 1 (main contactor for DC+). Activates the main HV line to EV.

Pin	Schematic Pin	Signal Name	Type of Signal	Description
E2	17	LockMotor-_1	Output	Controls the negative terminal of the locking actuator in the EV inlet. Ensures the connector cannot be removed during charging.
E3	18	LockMotor+_1	Output	Positive terminal of the locking actuator in the EV inlet. EVCC drives a full H-bridge for locking and unlocking.
D1	19	hvsw1_ls_1	Output	Low -side control of HV Switch 1 (main contactor for DC+). Activates the main HV line to EV.
D2	20	GND	Supply	Ground reference.
D3	21	pt1000_2	Input	Temperature sensor input 2.
C1	22	HV_VCC	Supply	Supply out for lock coils, motor, etc.
C2	23	HV_VCC	Supply	Supply out for lock coils, motor, etc.
C3	24	pt1000_1	Input	Temperature sensor input 1.
B1	25	hvsw2_ls_1	Output	Low -side control of HV Switch 2 (main contactor for DC-). Activates the main HV line to EV.
B2	26	hvsw2_hs_1	Output	High-side control of HV Switch 2 (main contactor for DC-). Activates the main HV line to EV.
B3	27	ild1_1	Input	Reads back interlock detector confirms that the physical interlock circuit is closed (connector engaged). Critical for safety before HV enable.
A1	28	fc1_1	Input	Fault input 1
A2	29	fc0_1	Input	Fault input 0
A3	30	ild2_1	Input	Reads back interlock detector confirms that the physical interlock circuit is closed (connector engaged). Critical for safety before HV enable.

B. J2 Connector (18-Pin)

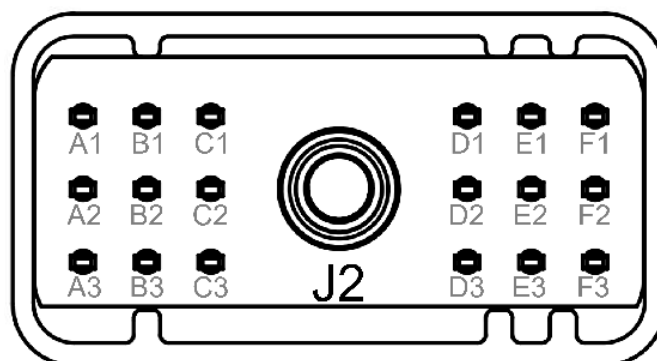

Figure 5 J2 Connector (18-Pin).

Table 3 J2 Connector (18-Pin).

Pin	Schematic Pin	Signal Name	Type of Signal	Description
F1	31	WU_IN_1	Input	Wake-up signal from ignition or vehicle line. Wakes EVCC from low-power or standby mode.
F2	32	LockFbk+_1	Input	Feedback from the locking mechanism. Confirms the connector is locked.
F3	33	pt1000_4	Input	Temperature sensor input 4.
E1	34	HVSW1_Fbk_1	Input	Feedback from main contactor DC+. EVCC monitors this before enabling current.
E2	35	HVSW2_Fbk_1	Input	Feedback from main contactor DC-. EVCC monitors this before enabling current.
E3	36	pt1000_3	Input	Temperature sensor input 3.
D1	37	SensorSupply_out	Supply	Supply output for external sensors
D2	38	HMISupply_out	Supply	Supply output for HMI
D3	39	led1	Output	Indication LED1
C1	40	ilg2_1	Input	The interlock generator channel is used if dual interlock circuits are present. Signals safe HV engagement.
C2	41	ilg1_1	Input	The interlock generator channel is used if dual interlock circuits are present. Signals safe HV engagement.
C3	42	led4	Output	Indication LED4
B1	43	btn_1	Input	Button input (user press or emergency release).

Pin	Schematic Pin	Signal Name	Type of Signal	Description
B2	44	GND	Supply	Ground reference.
B3	45	led3	Output	Indication LED3
A1	46	VCC_24V_IN	Supply	Operational supply Input to EVCC (+24V)
A2	47	VCC_24V_IN	Supply	Operational supply Input to EVCC (+24V)
A3	48	led2	Output	Indication LED2

6. Cable Management

This cable assembly procedure applies to crimp-type terminals and sealed connectors (18-pin or 30-pin configuration), which are used especially for EVCC.

6.1 Prerequisites

Table 4 Tools and Equipment for Cable Management.

No.	Tools & Equipment	Part Number
1.	Mating Connector	J1 30-Pin: 5810130029 J2 18-Pin: 5810118023
2.	Crimp Terminal	4250000872
3.	Wire	-
4.	Tweezer	5991111628
5.	Crimping Tool	5991111615
6.	Wire Stripping	-
7.	Terminal Insertion / Removal Tools	5810118920

6.2 Technical Requirements

A. Wire Specification

- Wire Type and Gauge: 16 AWG TXL,
18 AWG TXL,
20 AWG GXL
- Insulation: Automotive Grade

B. Strip Length

- Standard Strip Length: 4.35 mm ± 0.2 mm

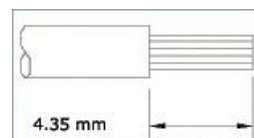

C. Crimp Quality

- No exposed conductor strands
- Proper insulation support
- Symmetrical Crimp

D. Reference

- Pin configuration (*Section 2.3.4*)
- Mechanical Design of the Connector and Terminal (*Appendix A*)

6.3 Procedure

6.3.1 Wire and Terminal

Step 1 Wire Cutting

1. Cut wires according to requirements.
2. Ensure a clean, perpendicular cut.

Step 2 Wire Stripping

1. Strip insulation to the specified length.
2. Avoid nicking or cutting conductor strands.
3. Verify strip length using measuring tool.

Step 3 Terminal Crimping

1. Load the terminal into the crimp tool locator.



Figure 6 Load the terminal.

2. Insert stripped wire into the terminal barrel. Ensure correct positioning of insulation.



Figure 7 Insert stripped wire.

3. Press or activate the crimp tool until the full cycle completes.



Figure 8 Press the crimp tool.

4. Remove crimp wire.



Figure 9 Remove crimp wire.

Inspection

- Conductor fully inside barrel
- Insulation is correctly supported
- No deformation or cracks

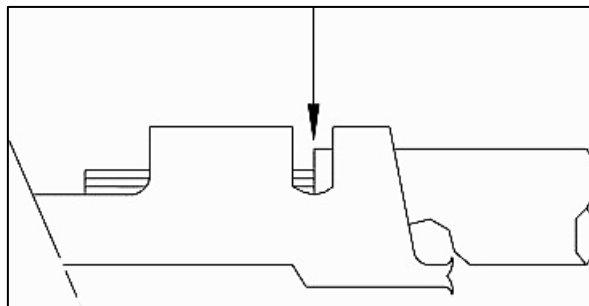

Figure 10 Inspect the wire and terminal.

6.3.2 Connector

Step 1 Preparation

1. Inspect a connector for damage.
2. Ensure secondary lock is in pre-open position.

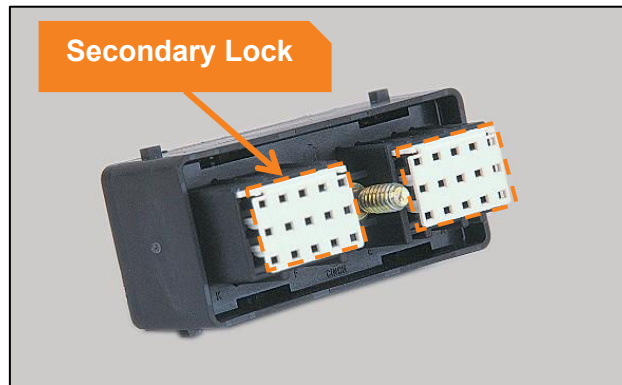

Figure 11 Pre-open position of the secondary lock.

Step 2 Terminal Insertion

1. Hold a connector with a cavity marking upright.
2. Align a terminal's polarization ears.

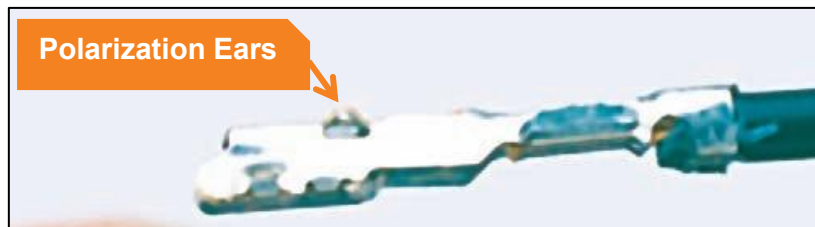

Figure 12 Position of the terminal's polarisation ears.

3. Insert the terminal straight into the cavity.

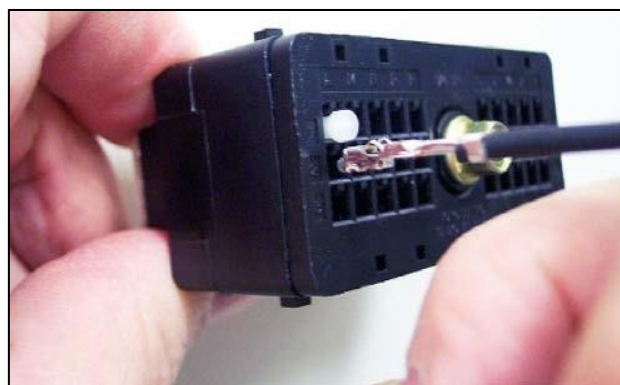

Figure 13 Insert the terminal in a cavity.

4. Push until an audible/tactile click is achieved.
5. Perform a tug test to confirm locking.

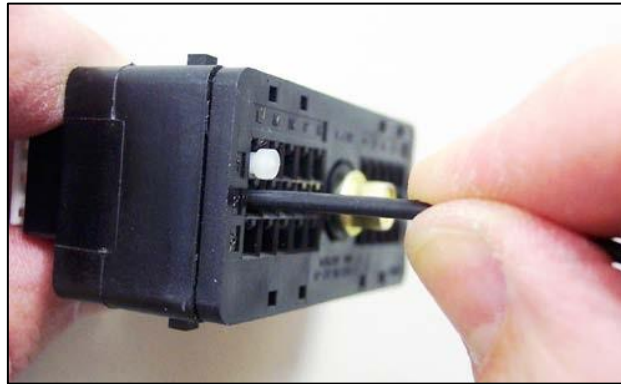

Figure 14 Tug test to confirm locking.

Step 3 Wire Loading Sequence

1. Populate a middle row first.



Figure 15 Wires in the middle row.

2. Continue with outer rows.



Figure 16 wires in the outer rows.

Step 4 Secondary Locking

1. Close a secondary lock after all terminals are inserted.
2. Ensure a lock is fully engaged.
3. If resistance is felt:
 - Stop immediately.
 - Check for unseated terminals.

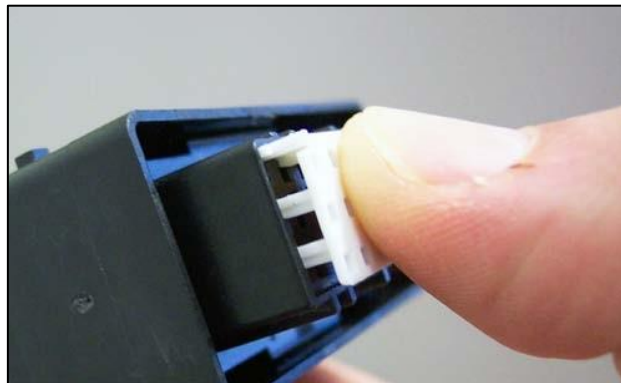

Figure 17 Insert the secondary lock.

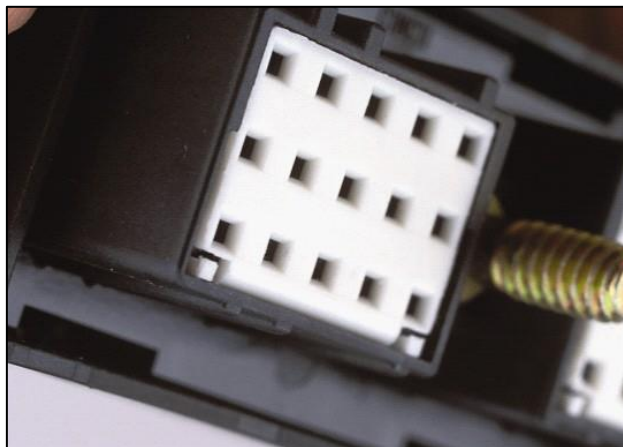

Figure 18 Closed secondary lock.

Step 5 Harness Dressing

1. Maintain a minimum of 50 mm from a connector to the first tie point.

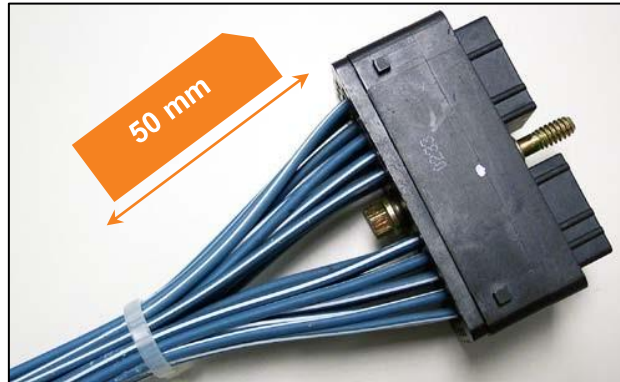

Figure 19 First tie point at 50mm.

2. Secure the harness using conduit, cable ties or tape.

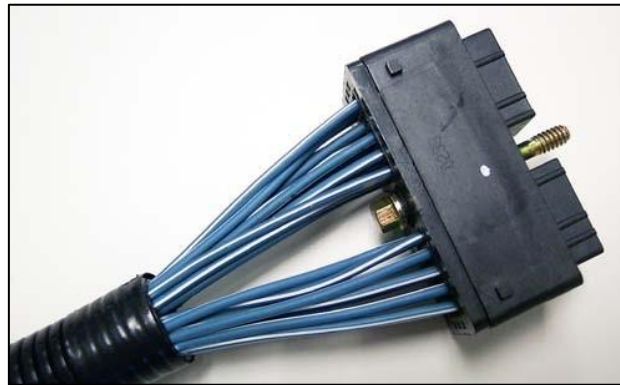

Figure 20 Secure harness cable.

3. Avoid sharp bends or tense points.

6.3.3 Inspection & Quality Check

Step 1 Visual Inspection

- Connector Intact
- Terminal fully seated
- No Insulation Damage
- Seal Plugs Present

Step 2 Mechanical Check

- Tug Test for Each Wire
- Verify Secondary Lock Engagement

Step 3 Electrical Test

- Continuity Test
- Short Circuit Check
- Pin-to-Pin Verification.

6.3.4 Rework Procedure

1. Open the secondary lock using the tweezers.

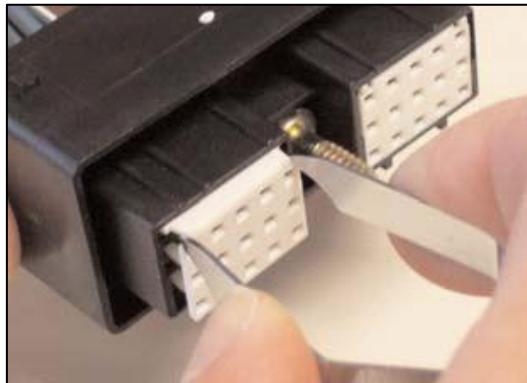

Figure 21 Open the secondary lock.

2. Insert the terminal removal tool into the cavity.

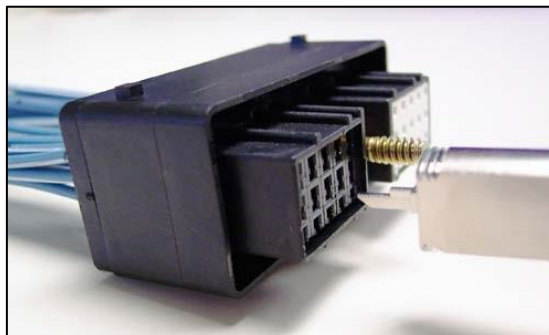

Figure 22 Position of the terminal removal tool.

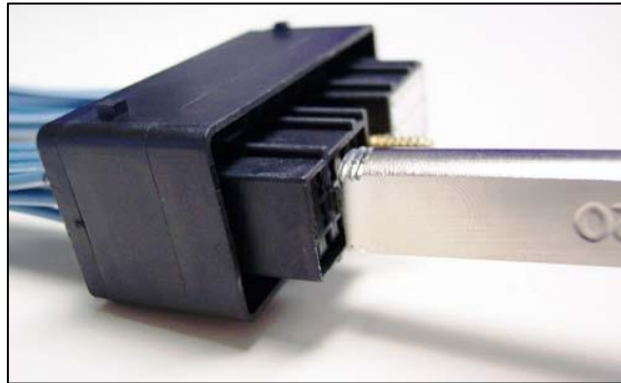

Figure 23 Insert the terminal removal tool in the cavity.

3. Release locking tab.
4. Pull the wire gently to remove the terminal.

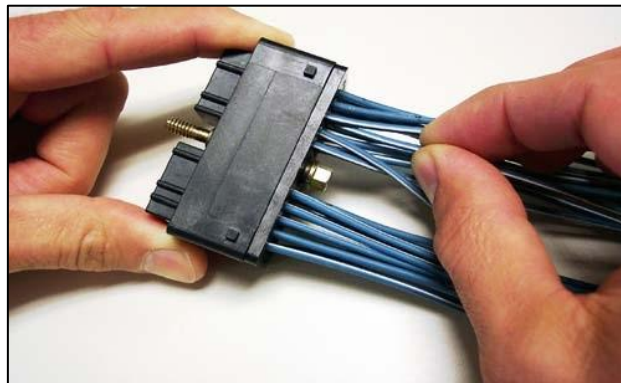

Figure 24 Pull the wire to remove the terminal.

5. Replace the terminal if damaged.

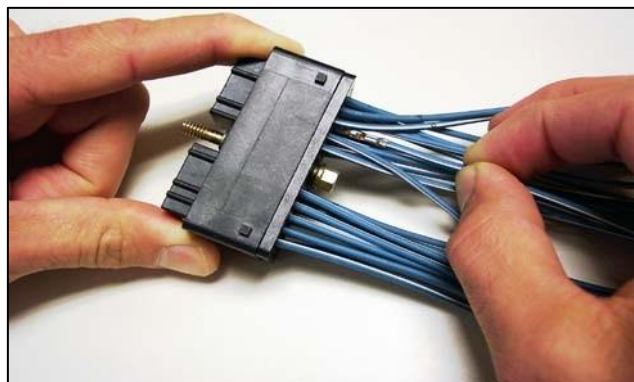

Figure 25 Replace the terminal if damaged.

Appendix

Appendix A Mechanical Design

Refer to the next page

Appendix A1 J1 30-Pin Connector

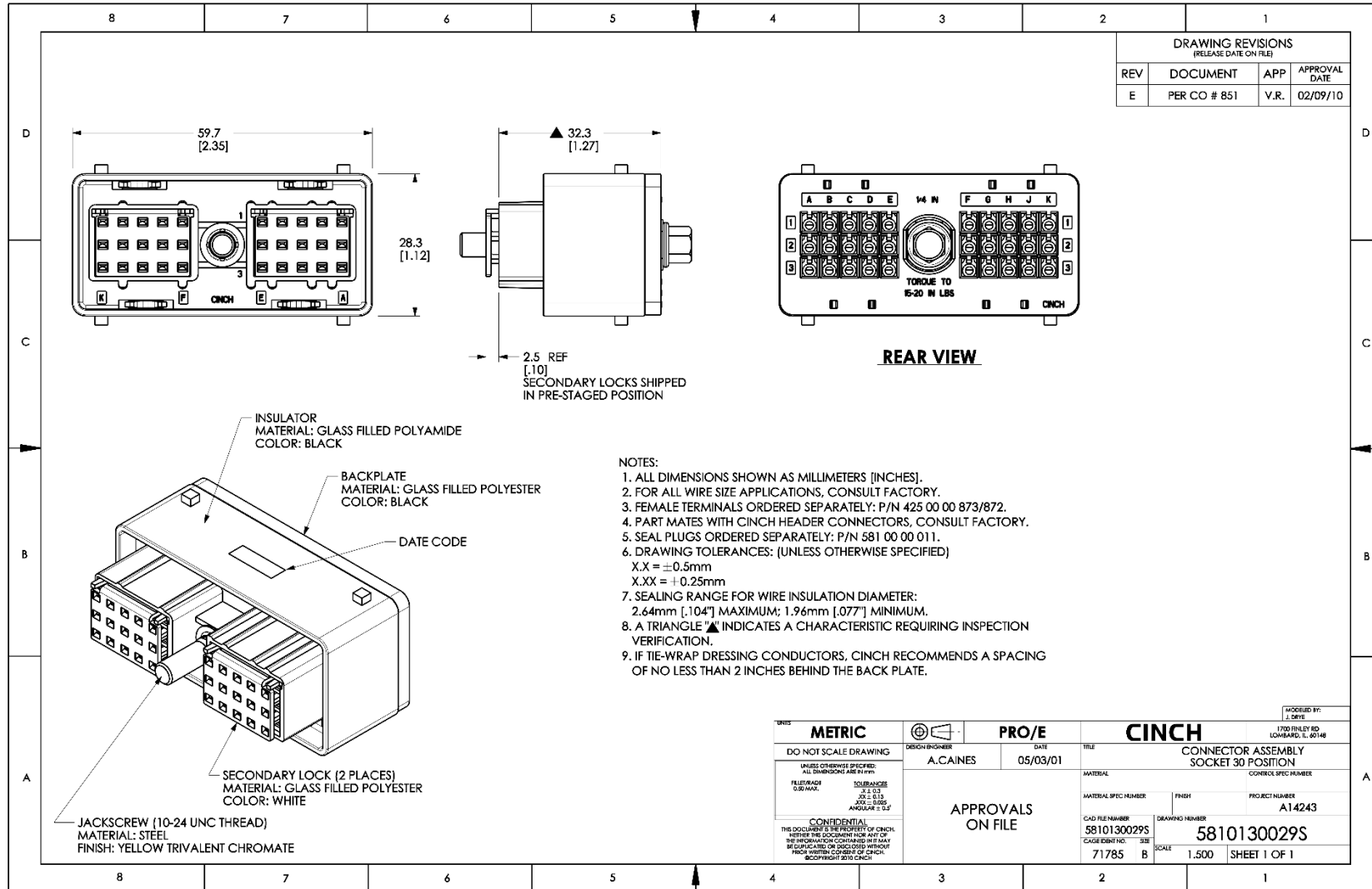

Appendix A2 J2 18-Pin Connector

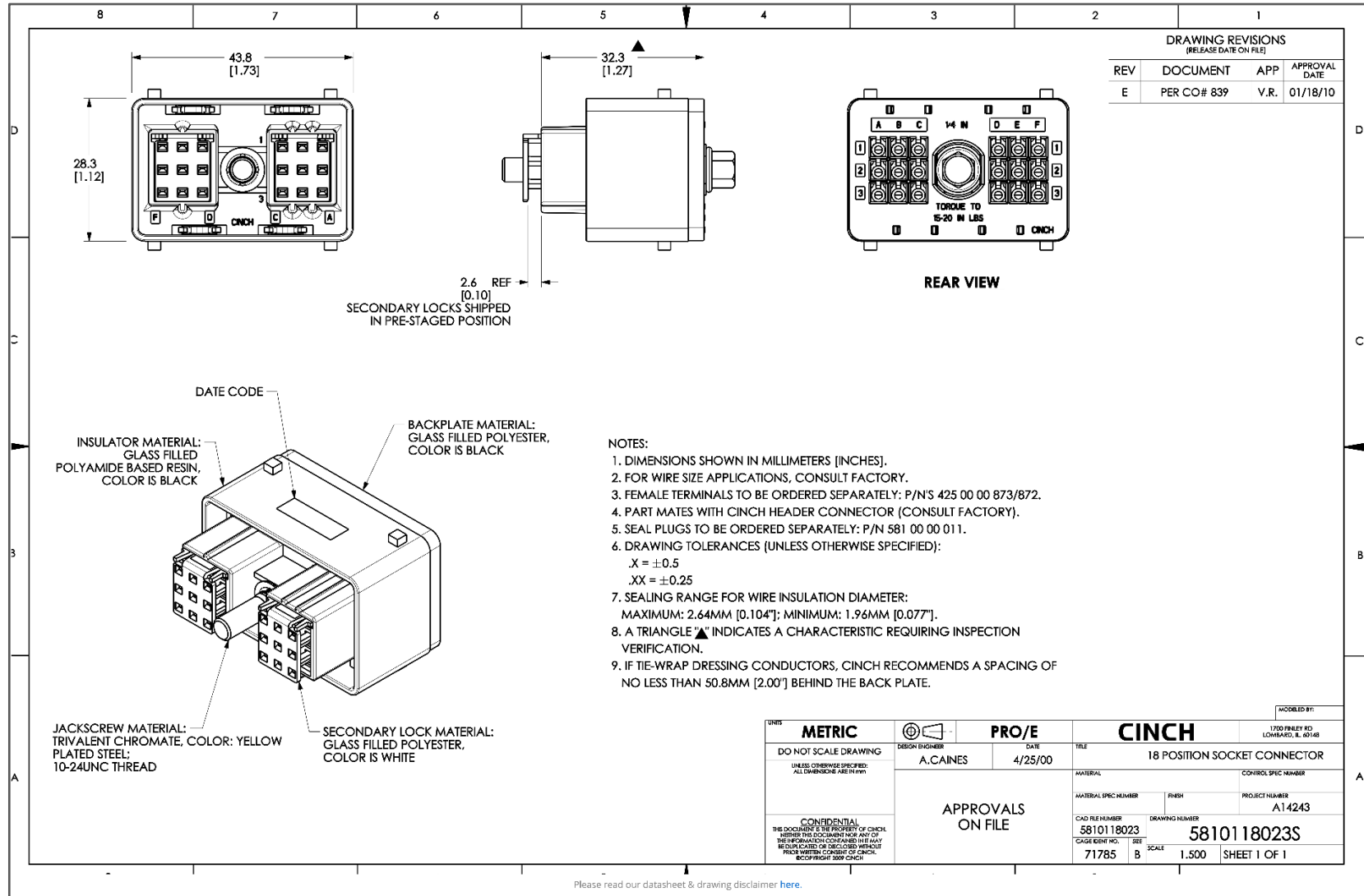

Appendix A3 Terminal

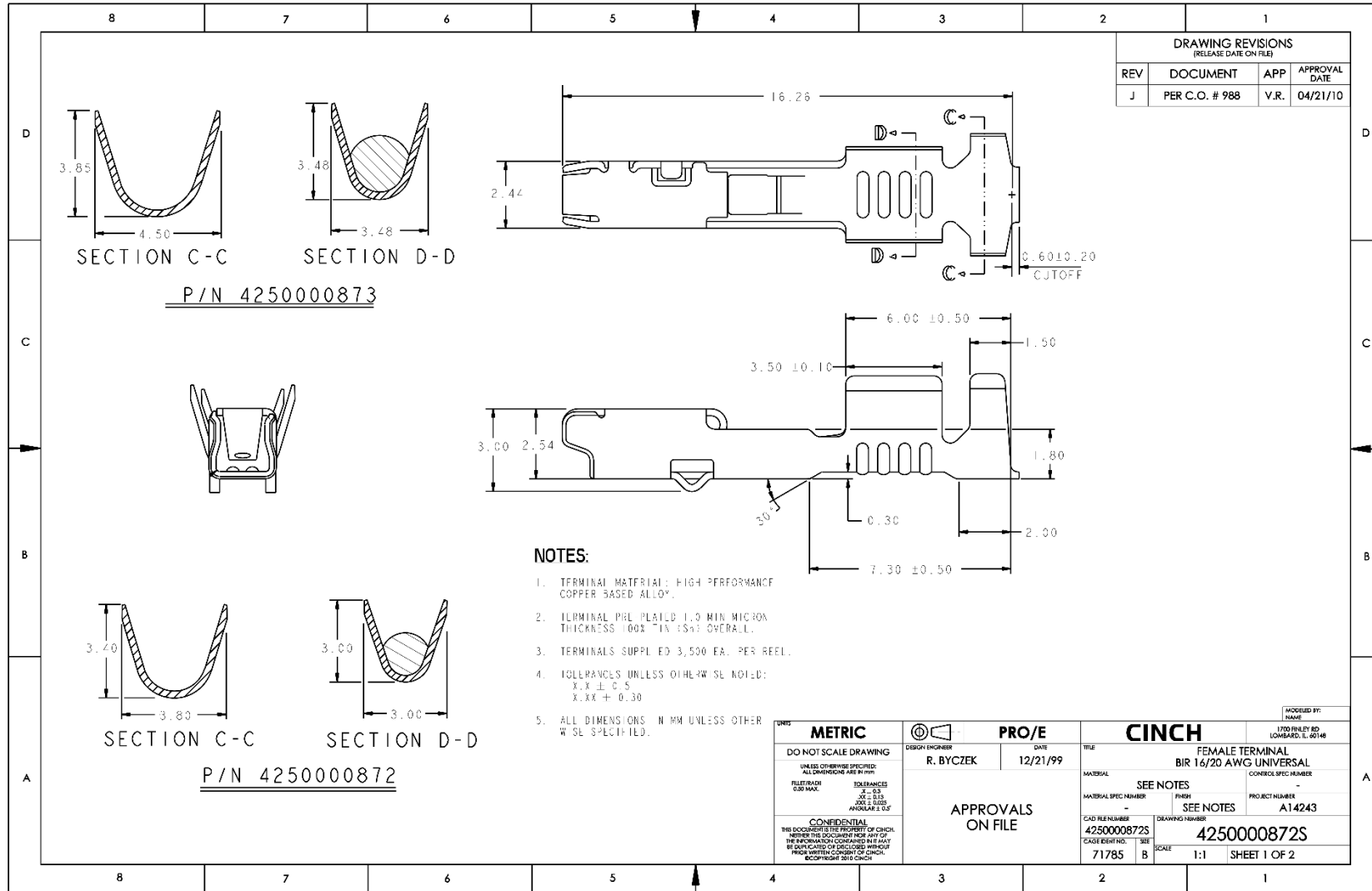

Appendix B Abbreviations and Glossary

°C	<i>The degree Celsius (symbol: °C) can refer to a specific point on the Celsius temperature scale or to a difference or range between two temperatures.</i>
AWG	<i>American Wire Gauge (AWG) is a North American standard system for measuring the diameter of solid, round, non-ferrous electrical conductors. A lower AWG number indicates a thicker wire, while a higher number indicates a thinner wire. It is crucial for determining electrical resistance, allowable ampacity, and physical size.</i>
BMS	<i>BMS stands for Battery Management System. It is an electronic system that acts as the "brain" of the battery pack, ensuring safe operation, monitoring states (voltage, temperature, capacity), balancing cells, and protecting against overcharging or overheating to maximise battery life.</i>
CAN	<i>A controller area network (CAN) bus is a high-integrity serial bus system for networking intelligent devices. CAN buses and devices are common components in automotive and industrial systems.</i>
CCS2	<i>Combined Charging System 2</i>
CP	<i>Control Pilot is a communication line used to negotiate charging levels between the car and the EVSE, and it can be manipulated by the vehicle to initiate charging and carry other information.</i>
dB	<i>Decibel (dB), a unit for expressing the ratio between two physical quantities, usually amounts of acoustic or electric power, or for measuring the relative loudness of sounds. One decibel (0.1 bel) equals 10 times the common logarithm of the power ratio.</i>
DC	<i>Direct current (DC) is one-directional flow of electric charge.</i>
DIN 70121	<i>DIN 70121 (specifically DIN SPEC 70121) is a German technical standard defining digital communication between electric vehicles (EVs) and DC charging stations (EVSE) within the Combined Charging System (CCS).</i>
EV	<i>An EV is defined as a vehicle that can be powered by an electric motor that draws electricity from a battery and is capable of being charged from an external source.</i>
GND	<i>GND stands for Ground. A common or shared return route of electrical current to the power source that enables the completion of the circuit is referred to as the ground in both electrical and electronic circuits.</i>

GXL	<i>GXL stands for General Purpose Cross-Linked polyethylene insulated wire. It is a thin-wall, high-temperature automotive primary wire designed for engine compartments and circuits requiring superior heat (-40°C to +125°C) and abrasion resistance, commonly complying with SAE J1128 standards.</i>
H-Bridge	<i>An H-Bridge is an electronic circuit consisting of four switching elements that allow for bidirectional control of electrical current.</i>
HMI	<i>Human-Machine Interface</i>
HV AC	<i>High Voltage Alternating Current</i>
HV DC	<i>High Voltage Direct Current.</i>
IP	<i>Ingress Protection (IP) ratings, which grade the resistance of an enclosure against the intrusion of dust or liquids.</i>
ISO 15118	<i>ISO 15118, titled “Road Vehicles–Vehicle to Grid Communication Interface,” is an international standard defining bidirectional communication between electric vehicles (EVs) and charging stations (EVSE).</i>
ISO 26262 ASIL-B	<i>ISO 26262 ASIL-B (Automotive Safety Integrity Level B) is a mid-level risk classification for vehicle components, requiring moderate rigour in safety measures to mitigate potential hazards.</i>
LED	<i>A light-emitting diode (LED) is a semiconductor device that emits light when current flows through it.</i>
mm	<i>The millimetre is a unit of length in the International System of Units (SI), equal to one thousandth of a metre.</i>
PE	<i>A protective earth connection, earth ground, or safety ground uses a protective conductor to safely direct a fault current into the earth and away from a human being in contact.</i>
PP	<i>Proximity Pilot, aka “plug present,” provides a signal to the vehicle’s control system so it can prevent movement while connected to the electric vehicle supply equipment (EVSE, i.e., the charging station) and signals the latch release button to the vehicle.</i>
PT1000	<i>The first part of the name PT1000, “PT”, is the chemical symbol for Platinum, and this shows that the sensor is Platinum-based. The second part, 1000, indicates the nominal resistance of the sensor at 0°C.</i>
PWM	<i>Pulse Width Modulation (PWM) is a technique for controlling analog power using digital signals by switching a power source on and off rapidly.</i>

SAE J1939	<i>SAE J1939 is a set of high-speed communication protocol standards defined by the Society of Automotive Engineers (SAE), acting as a standardised language for electronic control units (ECUs) in heavy-duty vehicles, trucks, buses, and off-highway machinery.</i>
TXL	<i>TXL wire is a thin-wall, cross-linked polyethylene insulated cable used in automotive applications for high-temperature, lightweight, and durable wiring.</i>
VCU	<i>VCU stands for Vehicle Control Unit. It acts as the central brain or master controller, managing the powertrain, battery efficiency, torque, and safety systems.</i>
VDC	<i>VDC refers to volts of direct current, and it can come from either a battery or a power supply that converts AC (alternating current) into DC.</i>

 **Bacancy Systems PVT LTD,**
15-16, Times Corporate Park,
Near Thaltej-Shilaj Road,
Opp. Copper Stone Flats,
Thaltej, Ahmedabad,
Gujarat, India, 380059

 www.bacancysystems.com

 systems@bacancysystems.com

 +91 90160 28817

 **Helpdesk:** <https://bacancy.freshdesk.com/a/dashboard/default>